



# DURATECH<sup>®</sup>



**Manual 1: Operating Instructions**

# 3010<sup>™</sup>

## Tub Grinder

Includes: Stationary Electric Supplement



PRODUCT INFORMATION



0500113 • JUNE 2019

DURATECH INDUSTRIES INTERNATIONAL INC.  
PO BOX 1940, JAMESTOWN, ND 58402-1940  
TEL: (701) 252-4601 • FAX: (701) 252-0502  
WWW.DURATECHINDUSTRIES.NET • WWW.HAYBUSTER.COM



 **DURATECH<sup>®</sup>**  
*Clearing the Way for a Better Tomorrow*



# **3010<sup>TM</sup>**

## **Tub Grinder**


**Includes: Stationary Electric Supplement**

# **Manual 1:**

## **Operating Instructions**

DuraTech Industries International Inc. (DuraTech) has made every effort to assure that this manual completely and accurately describes the operation and maintenance of the 3010<sup>TM</sup> Tub Grinders as of the date of publication. DuraTech reserves the right to make updates to the machine from time to time. Even in the event of such updates, you should still find this manual to be appropriate for the safe operation and maintenance of your unit.

This manual, as well as materials provided by component suppliers to DuraTech are all considered to be part of the information package. Every operator is required to read and understand these manuals, and they should be located within easy access for periodic review.

 **DURATECH**® is a registered trademark of Duratech Industries International, Inc. 3010 is a trademark of Duratech Industries International, Inc.

---



 **DURATECH<sup>®</sup>**  
*Clearing the Way for a Better Tomorrow*





## Foreword

### **All personnel must read and understand before operating unit**

DuraTech Industries International Inc. (DuraTech Industries) has made every effort to assure that this manual completely and accurately describes the operation and maintenance of this Industrial Grinder as of the date of publication. DuraTech Industries reserves the right to make updates to the machine from time to time. Even in the event of such updates, you should still find this manual to be appropriate for the safe operation and maintenance of your machine.

This manual, as well as materials provided by component suppliers to DuraTech Industries are all considered to be part of the information package. Every operator is required to read and understand these manuals. All manuals should be located within easy access for troubleshooting and periodic review.

### **Appropriate use of the unit**

This Industrial Grinder is designed to grind wood waste and other materials, including: grass clippings, leaves, pallets, construction and demolition debris, tree branches and tree trunks.

It is **NOT** designed to grind rocks, steel, concrete, or the like.

### **Operator protection**

As with all machinery, care needs to be taken by the operator in order to insure the safety of the operator and those in the surrounding area.



**WARNING:** Operators and those observing the operation of the Industrial Grinder are required to wear head, eye, and ear protection. No loose clothing is allowed.



**TABLE OF CONTENTS**

**3010 TUB GRINDER Manual 1: Operators Instructions...1**

**Introduction ..... 2**  
**Purpose ..... 2**

**Section 1: Safety..... 4**

1.1 Safety-alert symbols ..... 5  
1.2 Operator - personal equipment..... 7  
1.3 Machine safety labels ..... 8  
1.4 Shielding..... 12  
1.5 Tub Grinder safety review ..... 12  
1.6 Thrown objects and operator safety ..... 14  
1.7 Service and maintenance ..... 15  
1.8 Personal protection equipment ..... 16  
1.9 Fire Prevention ..... 16  
1.10 Fire Extinguishers ..... 17  
1.11 Important safety reminders..... 18  
1.12 Towing..... 18

**Section 2: Introduction ..... 19**

2.1 Description of the 3010 DuraTech Tub Grinders ..... 19  
2.2 Electronic governor ..... 19  
2.3 Wet clutch ..... 21  
2.4 Rotor..... 21  
2.5 Screens ..... 21  
2.6 Tub..... 22  
2.7 Hydraulic cooler ..... 22  
2.8 Wet clutch cooler ..... 22  
2.9 The conveyor system..... 22  
2.10 Tub cover (optional) ..... 23  
2.11 Control panel ..... 23  
2.11b Control panel (S.N. 3130 And Up)..... 25  
2.12 Other controls..... 26

**Section 3: Operation ..... 27**

3.1 Pre-operation inspection..... 27  
3.2 Starting the Tub Grinder..... 28  
3.3 If the engine fails to start..... 28  
3.4 Throttle operation ..... 28  
3.5 Automatic engine shutdown system ..... 29  
3.6 Normal shutdown procedure ..... 29  
3.7 Emergency shutdown procedure ..... 29



## TABLE OF CONTENTS

3.8	Parts of the electronic governor .....	30
3.9	Operation of the electronic governor .....	31
3.10	Calibration of the electronic governor .....	32
3.11	Adjusting the tub's rotation speed .....	32
3.12	Raising the tub.....	32
3.13	Lowering the tub .....	33
3.14	Starting and stopping the belly and discharge conveyors .....	34
3.15	Lifting the discharge conveyor.....	34
3.16	Pivoting the discharge conveyor .....	34
3.17	Operating the grinder using the remote radio option .....	35
3.18	Grinding .....	37
3.19	Grinding with tub cover .....	37
3.20	Loading the tub.....	37
3.21	If lodging occurs while grinding .....	38
3.22	Grinding wet material.....	38
3.23	Preparing the 3010 DURATECH TUB GRINDER for transport.....	38
3.24	Preparing the 3010 DURATECH TUB GRINDER for operation after transport....	40
3.25	Preparing the 3010 DURATECH TUB GRINDER for storage .....	40
3.26	Removing the 3010 DURATECH TUB GRINDER from storage .....	41
3.27	Installing a screen.....	41
3.28	Adjusting the conveyor belt tension .....	42
3.29	Adjusting the conveyor belt tracking .....	43
3.30	Adjustable belly belt seals .....	44
3.31	Belt scrapers on belly and discharge conveyors.....	44
3.32	Adjusting tub chain tension .....	45
3.33	Engaging wet clutch .....	45
3.34	Disengaging the wet clutch .....	45
3.35	Electro-hydraulic valve coil test.....	46
3.36	Electro-hydraulic valve calibration (for SN up to GJ 3090) .....	47
3.36a	Electro-hydraulic valve calibration (for SN GJ 3090 and up).....	48
3.37	3010 Grapple Loader Option .....	49
3.38	3010 Track Option.....	52
3.39	3010 Hydraulic Hammer Rod Puller (Optional).....	59
<b>Section 4: Engine Maintenance .....</b>		<b>62</b>
<b>Section 5: General Maintenance .....</b>		<b>62</b>
5.1	Welding Procedure .....	62
5.2	Batteries.....	64
5.3	Lubrication .....	64
5.4	Pressure roller lubrication .....	71
5.5	Rotor bearing lubrication (S.N. Up to HJ3114) .....	71



## TABLE OF CONTENTS

5.5a Rotor bearing lubrication - Dodge Imperial ISAF Bearing lubrication (SN IJ3115 & up) ....	71
5.6 Hydraulic system.....	72
5.7 Wet clutch system.....	73
5.8 Axle, wheels and tires.....	75
5.9 Brake component lubrication .....	75
5.10 Rotor bearing installation (SN up to HJ3114) .....	77
5.10a Dodge Rotor bearing installation (SN IJ3115 & up).....	81
5.11 Hammermill maintenance .....	85
5.12 Fixed hammer maintenance and replacement.....	86
5.13 Swinging hammer replacement and maintenance.....	87
<b>Section 6: Troubleshooting the 3010 DURATECH TUB GRINDER .....</b>	<b>92</b>
6.1 Troubleshooting the electronic governor system .....	92
6.2 General Troubleshooting.....	96
6.3 Troubleshooting Omnex Wireless Remote Controls.....	97
6.4 Troubleshooting The Caterpillar Tier I Engine .....	100
6.5 Troubleshooting The Caterpillar C9 and C15 Tier III Engines and The Caterpillar C27 Tier II Engine.....	101
3010EL Electric Tub Grinder Operators Manual Supplement.....	102
Supplement Section 1: Start-Up.....	102
Supplement Section 2: Shut-Down Procedure.....	103
Supplement Section 3: Lubrication .....	104
Supplement Section 4: Raising/lowering the tub platform, raising/lowering the discharge conveyor, and folding/unfolding the discharge conveyor.....	105
Supplement Section 5: Hydraulic cooler.....	106
Supplement Section 6: Control Panel.....	107
Supplement Section 7: Belt Deflection .....	108
<b>Appendix A: Warranty .....</b>	<b>110</b>
<b>Appendix B: SPECIFICATIONS.....</b>	<b>111</b>
<b>Appendix C: Operator Training Form.....</b>	<b>113</b>
<b>3010 DURATECH TUB GRINDER Documentation Comment Form.....</b>	<b>115</b>



# **3010<sup>TM</sup>**

## **Tub Grinder**

**Includes: Stationary Electric Supplement**

# **Manual 1:**

## **Operating Instructions**



# Introduction

This Industrial Grinder is designed to grind wood waste and other materials, including grass clippings, leaves, pallets, construction and demolition debris, tree branches and tree trunks. It is **NOT** designed to grind rocks, steel, concrete, or the like.

## Purpose

The purpose of this owner's manual is to explain maintenance requirements, safety, and routine adjustments for the most efficient operation of your 3010DuraTech Tub Grinder. There is also a trouble shooting section that may help in case of problems in the field. Any information not covered in this manual may be obtained from your dealer.



**SPECIAL NOTE:** When reference is made as to front, rear, left hand, or right hand of this machine, the reference is always made from standing at the rear end of the machine and looking toward the hitch. Always use serial number and model number when referring to parts or problems. Please obtain your serial number and write it below for your future reference.

MODEL: 3010 DuraTech Tub Grinder      SERIAL NO. \_\_\_\_\_

## How to use this manual

### Manual organization

This manual is organized into the following parts:

- **Manual 1: Operating instructions** explain how to set up, use and maintain the 3010 DuraTech Tub Grinder.
- **Manual 2: Parts reference** contains diagrams of each assembly with the number of each part identified. A key on the facing page contains a description of the part and the quantity used.



## Operator responsibilities

- The operator is responsible for his or her own safety.
- The operator is responsible for the safety of all others in the area.
- Review “Dealer Responsibilities,” to verify that the machine has been prepared for use.
- Note the important safety information in the Foreword and in Section 1, “Safety.”
- Thoroughly review sections 1 through 3 which explain normal operation of the machine, and section 4 and 5 which explain maintenance requirements. These sections will function as a textbook during the dealer-conducted training course that is required before use of the unit.
- When all primary operators have read the operating instructions and understand all information concerning the safe operation of the unit, the dealer will be required to sign the User Training Verification Form found in the 3010 DURATECH TUB GRINDER documentation packet.



**NOTE:** This form requires both the dealer’s signature and the customer’s signature. The dealer is responsible for returning the signed form to DuraTech Industries.

- Manuals for certain third-party components are provided separately. The operator must also be familiar with their contents.
- Keep copies of all manuals in a readily-accessible location for future reference.





## Section 1: Safety

Thank you for taking the time to read the operation and maintenance manual for the DuraTech Industries 3010 DuraTech Tub Grinder. Because your safety and that of others is of the utmost importance, you should familiarize yourself with this entire manual before operating this unit.

The 3010 DURATECH TUB GRINDER incorporates a number of third party products. For example, the engine, and fluid clutch are third party products. More information about the operation and care of these products can be found in each product's respective manual(s). Before operating this unit, you should familiarize yourself with these manuals as well.

Safety is an ongoing job requirement, and DuraTech Industries has made every effort to make sure that the 3010 DuraTech Tub Grinder provides operator security and comfort. DuraTech Industries encourages you to bring to our attention as quickly as possible any suggestions you may have concerning the safety of the equipment. DuraTech Industries is dedicated to enhancing the safety of the DuraTech Industries 3010 DuraTech Tub Grinder.

This unit is supplied with an operation and maintenance manual and this manual should be kept with the unit for periodic review by operational personnel.

Operators of the 3010 DURATECH TUB GRINDER are recommended to wear head, eye, and ear protection as well as clothing appropriate for the application. Individuals with loose clothing, unrestrained long hair, jewelry, or other accessories which may hang loosely away from the body should not be allowed on or near the machine.



**WARNING:** FAILURE TO COMPLY WITH SAFETY INSTRUCTIONS THAT FOLLOW WITHIN THIS MANUAL COULD RESULT IN SEVERE PERSONAL INJURY OR DEATH. BEFORE ATTEMPTING TO OPERATE THIS MACHINE, CAREFULLY READ ALL INSTRUCTIONS CONTAINED WITHIN THIS MANUAL.

**THIS MACHINE IS NOT TO BE USED FOR ANY PURPOSE OTHER THAN THOSE EXPLAINED IN THE OPERATOR'S MANUAL, ADVERTISING LITERATURE OR OTHER DURATECH INDUSTRIES WRITTEN MATERIAL PERTAINING TO THE 3010 DURATECH TUB GRINDER.**



## 1.1 Safety-alert symbols (REV. 06-14)

Decals are illustrated in **Manual 2: Parts Reference**.

The safety decals located on your machine contain important and useful information that will help you operate your equipment safely.

To assure that all decals remain in place and in good condition, follow the instructions below:

- Keep decals clean. Use soap and water - not mineral spirits, adhesive cleaners and other similar cleaners that will damage the decal.
- Replace all damaged or missing decals. When attaching decals, surface temperature of the machine must be at least 40° F (5° C). The surface must be also be clean and dry.
- When replacing a machine component to which a decal is attached, be sure to also replace the decal.
- Replacement decals can be purchased from your DuraTech dealer.

DuraTech Industries uses industry accepted ANSI standards in labeling its products for safety and operational characteristics.



### Safety-Alert Symbol

Read and recognize safety information. Be alert to the potential for personal injury when you see this safety-alert symbol.

**DANGER:** Indicates an imminently hazardous situation that, if not avoided, will result in death or serious injury. This signal word is to be limited to the most extreme situations, typically for machine components that, for functional purposes, cannot be guarded.

**WARNING:** Indicates a potentially hazardous situation that, if not avoided, could result in death or serious injury, and includes hazards that are exposed when guards are removed. It may also be used to alert against unsafe practices.

**CAUTION:** Indicates a potentially hazardous situation that, if not avoided, may result in minor or moderate injury. It may also be used to alert against unsafe practices.



**DANGER:**

Signal word - White Lettering/Red Background  
Safety Alert Symbol - White Triangle/Red Exclamation Point



**WARNING:**

Signal word - Black Lettering/Orange Background  
Safety Alert Symbol - Black Triangle/Orange Exclamation Point



**CAUTION:**

Signal word - Black Lettering/Yellow Background  
Safety Alert Symbol - Black Triangle/Yellow Exclamation Point



This manual uses the symbols to the right to denote important safety instructions and information.

The **DANGER**, **WARNING** and **CAUTION** symbols are used to denote conditions as stated in the text above. Furthermore, the text dealing with these situations is surrounded by a box with a white background, will begin with **DANGER**, **WARNING**, or **CAUTION**.

The **INFORMATION** symbol is used to denote important information or notes in regards to maintenance and use of the machine. The text for this information is surrounded by a box with a light grey background, and will begin with either **IMPORTANT** or **NOTE**.



	<p>1. Yellow warning triangle/black graphical symbol, indicates what the hazard is. Hazard Identification</p>
	<p>2. Red circle-with-slash/black graphical symbol indicates a prohibited action to avoid the hazard. Prohibited Action</p>
	<p>3. Blue mandatory action circles/white graphical symbol - indicates an action to take to avoid the hazard. Mandatory Action</p>



## 1.2 Operator - personal equipment (REV. 06-19)

### THE OPERATOR

#### Physical Condition

You must be in good physical condition and mental health and not under the influence of any substance (drugs, alcohol) which might impair vision, dexterity or judgment.

Do not operate a 3010 DURATECH TUB GRINDER when you are fatigued. Be alert - If you get tired while operating your 3010 DURATECH TUB GRINDER, take a break. Fatigue may result in loss of control. Working with any industrial equipment can be strenuous. If you have any condition that might be aggravated by strenuous work, check with your doctor before operating

#### Proper Clothing



Clothing must be sturdy and snug-fitting, but allow complete freedom of movement. Avoid loosefitting jackets, scarfs, neckties, jewelry, flared or cuffed pants, unconfined long hair or anything that could become entangled with the machine.



Protect your head with a hard hat to reduce the risk of injury from flying debris.



Protect your hands with gloves when handling flail and sections. Heavyduty, nonslip gloves improve your grip and protect your hands.



Good footing is most important. Wear sturdy boots with nonslip soles. Steel-toed safety boots are recommended.



To reduce the risk of injury to your eyes never operate a **3010 DURATECH TUB GRINDER** unless wearing goggles or properly fitted safety glasses with adequate top and side protection.




Tractor noise may damage your hearing. Always wear sound barriers (ear plugs or ear muffers) to protect your hearing. Continual and regular users should have their hearing checked regularly.




### 1.3 Machine safety labels (REV. 06-14)

The safety decals located on your machine contain important information that will help you operate your equipment. Become familiar with the decals and their locations.

 **DANGER: OBJECTS THROWN BY MACHINE**  
DO NOT OPERATE WITHOUT WEARING SAFETY GLASSES AND A HARD HAT.  
KEEP UNAUTHORIZED PERSONNEL OUT OF THE GRINDING AREA




6500118

 **DANGER: ROTATING PART HAZARD, STAY OUT OF TUB WHEN ENGINE IS RUNNING.**

1. KEEP OTHERS AWAY.
2. PLACE ALL CONTROLS IN NEUTRAL, STOP ENGINE, REMOVE KEY, AND WAIT FOR ALL MOVING PART TO STOP BEFORE SERVICING, ADJUSTING, REPAIRING, UNPLUGGING, OR ENTERING THE TUB FOR ANY REASON.
3. DISCONNECT DRIVELINE ON PTO MODELS.



6500212


 **DANGER: ELECTROCUTION HAZARD**  
TO PREVENT SERIOUS INJURY OR DEATH FROM ELECTROCUTION:

STAY AWAY FROM POWER LINES WHEN OPERATING BOOM LOADER, FOLDING AND RAISING CONVEYORS, AND TRANSPORTING ON ROADS.

THIS MACHINE IS NOT GROUNDED, ELECTROCUTION MAY OCCUR WITHOUT DIRECT CONTACT.



6500216

 **WARNING: CHECK FOR FIRES, CLEAN OFF DEBRIS, SWITCH OFF BATTERY**  
**NEVER LEAVE THIS MACHINE UNATTENDED UNTIL ALL POTENTIAL FIRE DEBRIS IS REMOVED, NO FIRE OR SMOLDERING EXISTS, AND THE BATTERY IS SWITCHED OFF. REMOVE ALL FLAMMABLE DEBRIS FROM ENGINE, SHIELDING, CONTROL PANEL, UNDER MACHINE AND ANYWHERE MATERIAL IS COLLECTED.**

**DURATECH INDUSTRIES IS NOT RESPONSIBLE FOR FIRES CAUSED BY HAZARDS LEFT TO SMOLDER OR BURN, OR IMPROPER SHUTDOWN PROCEDURES.**





6500425



**WARNING: FOR YOUR PROTECTION AND SAFETY OF OTHERS, FOLLOW THESE SAFETY RULES**

1. READ AND UNDERSTAND OPERATORS MANUAL BEFORE OPERATING MACHINE.
2. PLACE ALL CONTROLS IN NEUTRAL, STOP ENGINE, REMOVE IGNITION KEY, LOCK OUT POWER SOURCE, AND WAIT FOR ALL MOVEMENT TO STOP BEFORE SERVICING, ADJUSTING, REPAIRING, OR UNPLUGGING.
3. READ AND UNDERSTAND ALL DECALS ON MACHINE FOR YOUR SAFETY.
4. KEEP ALL SHIELDS IN PLACE WHILE MACHINE IS IN OPERATION.
5. KEEP HANDS, FEET, HAIR, AND CLOTHING AWAY FROM MOVING PARTS.
6. KEEP OTHERS AWAY FROM MACHINE WHILE IN OPERATION.
7. INSTALL SAFETY LOCKS BEFORE TRANSPORTING, OR WORKING BENEATH COMPONENTS.
8. DO NOT ALLOW RIDERS AT ANY TIME.
9. DO NOT LEAVE MACHINE UNATTENDED WHILE ENGINE IS RUNNING.
10. KEEP ALL HYDRAULIC LINES, COUPLINGS, AND FITTINGS FREE OF LEAKS DURING OPERATION.
11. KEEP AWAY FROM OVERHEAD ELECTRICAL LINES. ELECTROCUTION CAN OCCUR WITHOUT DIRECT CONTACT.
12. REVIEW SAFETY INSTRUCTIONS PERIODICALLY.

 <b>WARNING</b>	 <b>ADVERTENCIA</b>
<b>FOR YOUR PROTECTION AND SAFETY OF OTHERS, FOLLOW THESE SAFETY RULES.</b> 1. Read and understand operators manual before operating machine. 2. Place all controls in neutral, stop engine, remove ignition key, lock out power source, and wait for all motion to stop before servicing, adjusting, repairing, or unplugging. 3. Read and understand all decals on machine for your safety. 4. Keep all shields in place while machine is in operation. 5. Keep hands, feet, hair, and clothing away from moving parts. 6. Keep others away from machine while in operation. 7. Install safety locks before transporting, or working beneath components. 8. Do not allow riders at any time. 9. Do not leave machine unattended with engine running. 10. Keep all hydraulic lines, couplings, and fittings free of leaks during operation. 11. Keep away from overhead electrical lines. Electrocution can occur without direct contact. 12. Review safety instructions periodically.	<b>PARA SU PROTECCIÓN Y LA SEGURIDAD DE OTROS, OBSERVE ESTAS NORMAS DE SEGURIDAD</b> 1. Lea y comprenda el manual del operador antes de operar la máquina. 2. Coloque todos los controles en punto neutro, apague el motor, quite la llave de encendido, bloquee la fuente de energía y espere a que se detenga todo el movimiento antes de proceder al servicio, ajuste, reparación o desenchufado. 3. Lea y comprenda todos los avisos de advertencia adheridos a la máquina para su seguridad. 4. Mantenga todos los dispositivos en su lugar mientras la máquina está en funcionamiento. 5. Mantenga las manos, pies, cabello y ropa lejos de las partes en movimiento. 6. No permita que otros monten en la máquina en funcionamiento. 7. Instale los dispositivos de bloqueo antes de transportar o trabajar debajo de los componentes. 8. No permita en ningún momento que otras personas estén en la máquina durante su funcionamiento. 9. No permita que otros operen la máquina sin su supervisión. 10. Mantenga libres las líneas hidráulicas, acoplamiento y conexiones en todo momento. 11. Permanezca alejado de las líneas eléctricas aéreas. Puede producirse la electrocución sin contacto directo. 12. Analice las instrucciones de seguridad en forma periódica.




6500208



**WARNING: TO PREVENT SERIOUS INJURY OR DEATH:**

**DO NOT WALK UNDER CONVEYOR AT ANY TIME. STAY CLEAR OF CONVEYOR DURING OPERATION, RAISING, AND LOWERING. LOWER CONVEYOR FULLY BEFORE SERVICING.**

**KEEP OTHERS AWAY.**

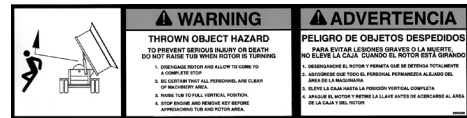
 <b>WARNING</b>	 <b>ADVERTENCIA</b>
 <b>OVERHEAD CONVEYOR HAZARD</b> To prevent serious injury or death: Do not walk under conveyor at any time. Stay clear of conveyor during operation, raising, or lowering. Lower conveyor fully before servicing. Keep others away.	<b>PELIGRO DE CINTA TRANSPORTADORA ELEVADA</b> Para evitar lesiones graves o la muerte: No camine por debajo de la cinta transportadora cuando esté funcionando, al subir o al bajar. Baje completamente la cinta transportadora antes de proceder al servicio. Manténgase alejado de la cinta transportadora durante su funcionamiento, al subir o al bajar. Baje completamente la cinta transportadora antes de proceder al servicio. Mantenga alejado a otras personas.

6500214



**WARNING: THROWN OBJECT HAZARD, TO PREVENT SERIOUS INJURY OR DEATH DO NOT RAISE TUB WHEN ROTOR IS TURNING.**

1. DISENGAGE ROTOR AND ALLOW TO COME TO A COMPLETE STOP.
2. BE CERTAIN THAT ALL PERSONNEL ARE CLEAR OF MACHINERY AREA.
3. RAISE TUB TO FULL VERTICAL POSITION.
4. STOP ENGINE AND REMOVE KEY BEFORE APPROACHING TUB AND ROTOR AREA.



6500209



**WARNING: HIGH-PRESSURE FLUID HAZARD, TO PREVENT SERIOUS INJURY OR DEATH:**

- RELIEVE PRESSURE ON SYSTEM BEFORE REPAIRING OR ADJUSTING OR DISCONNECTING.
- WEAR PROPER HAND AND EYE PROTECTION WHEN SEARCHING FOR LEAKS. USE WOOD OR CARDBOARD INSTEAD OF HANDS.
- KEEP ALL COMPONENTS IN GOOD REPAIR.



6500220




**WARNING: PINCH POINT STAY BACK**



6500339






 **WARNING: NO RIDERS**  
SERIOUS INJURY COULD RESULT FROM RIDING ON THE MACHINE.

<p> <b>WARNING</b></p> <p><b>No Riders</b> Serious personal injury could result from riding on the machine.</p>		<p> <b>ADVERTENCIA</b></p> <p><b>Pasajeros Prohibidos</b> Podrian resultar lesiones personales graves al viajar en la maquina.</p> <p><small>6500043</small></p>
---	---	---

6500043

 **DO NOT OPERATE MACHINE UNLESS AN APPROVED FIRE EXTINGUISHER IS INSTALLED.**



6500497

 **KEEP WHEEL BOLTS TIGHT**

**KEEP WHEEL BOLTS TIGHT**

**MANTENER AJUSTADOS LOS PERNOS DE LA RUEDA**

6500042

6500042



## 1.4 Shielding (REV. 01-03)

This Tub Grinder is equipped with heavy-duty shielding at major points of potential injury. All Shields should be kept in place during operation. Bodily injury may occur if the unit is operated without shields.



**WARNING:** Shields are installed for your protection and to keep material off machine parts. Do not operate this Tub Grinder without shields in place.

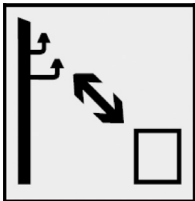
## 1.5 Tub Grinder safety review (REV. 06-14)



**WARNING:** Before attempting to operate your Tub Grinder, carefully read and follow instructions given below and contained elsewhere in this manual.

Each and every aspect of the **DuraTech Industries 3010 DuraTech Tub Grinder** should be reviewed by each operator on a frequent basis. Safety systems are in place that result in direct operator security.

- Keep all foreign objects such as rocks, pieces of metal and other incompressibles out of the tub and away from the mill. Foreign objects may result in personnel injury or damage to the machine. A foreign object is any object which the unit is not designed to grind.
- Allow only responsible, properly instructed and certified individuals to operate machines. Carefully supervise trainee operators.
- **Never operate the unit without all safety features, including shields, in place and in operating condition.**
- Make no modifications to this equipment unless specifically requested or recommended by DuraTech Industries.
- Tighten or replace any loose or cracked bolts, chains, hoses or connections.
- Check overhead for electrical power lines or other obstructions and be certain there is adequate clearance.



Keep sufficient distance away from electrical power lines.

**WARNING:** Electrocution is possible when running this machine during an electric storm or heavy fog.



- Allow no one on the Tub Grinder at any time during operation.



**Never allow riders on the machine at any time.**

- Unauthorized personnel should stay out of the grinding area.
- Always perform the pre-operation inspection before operating this machine.
- Ensure rotor is at a complete stop, engine is shut down, and the ignition key is removed before any performing any maintenance.
- **Never grab rope, cable, twine or similar material hanging out of tub while the tub grinder is running.**
- **Never enter the conveyor pivot area when the engine is running.**



**WARNING:** Loose clothing, necklaces and similar items are easily caught in moving parts. Avoid the use of these items if possible. Keep long hair confined. Keep hands, feet and clothing away from power driven parts.



## 1.6 Thrown objects and operator safety (REV. 01-03)

An operational characteristic of all grinders is that objects may be thrown out of the hopper. Thrown objects may present a safety hazard to persons in the area. This section is to inform the operator of this characteristic, and what can be done to reduce the risk of injury to the operator and persons in the area. Keep all observers away from the machine.

Figure shows an object being hit as the hammer is on the upswing. A general pattern for where thrown objects may land is shown in Figure 1.2.

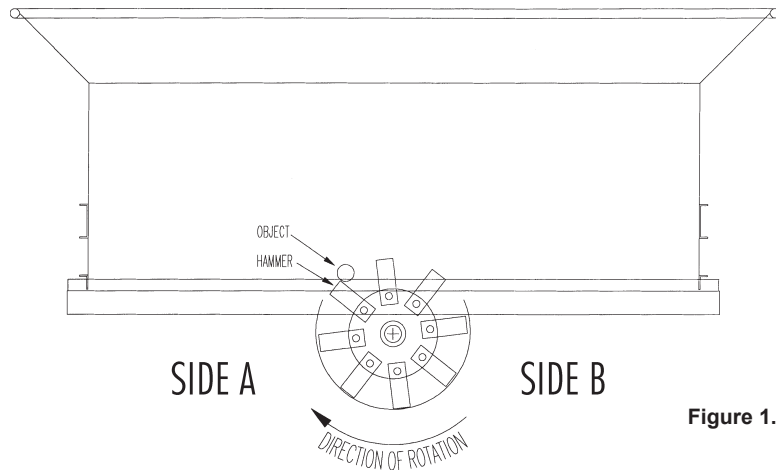


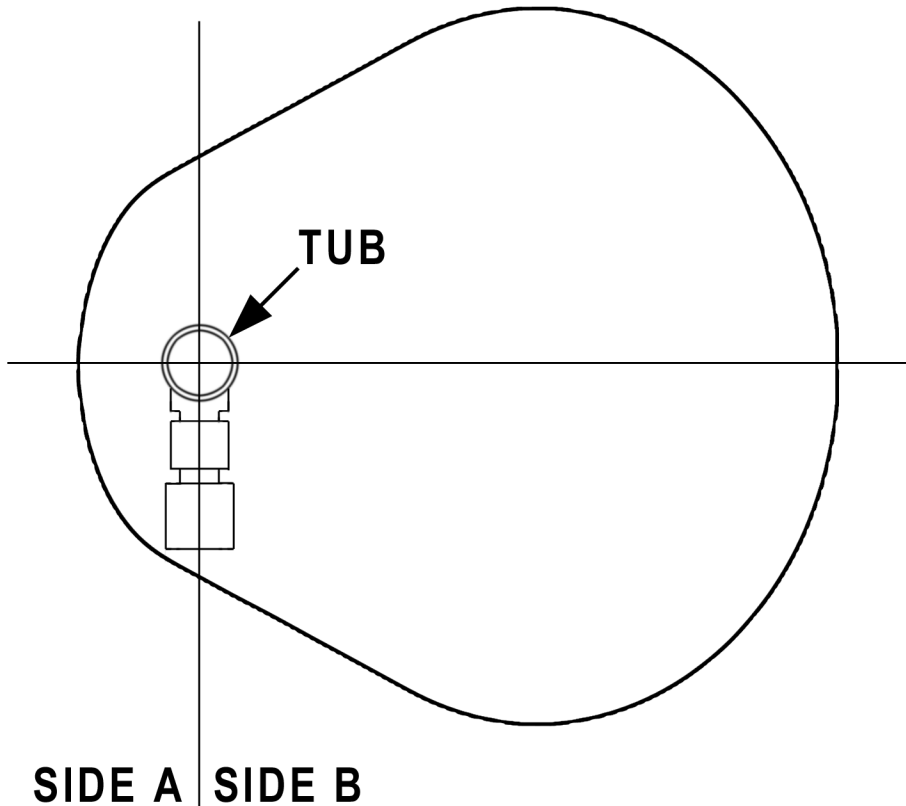
Figure 1.1



**NOTE:** The difference in the size of the area for side A versus side B. Side B is larger.

Dimensioning the size of this area is not practical. The distance a thrown object may travel is dependent on several conditions, including, but not limited to, rotor speed and diameter, condition of the hammers, style of hammers, object mass, object shape, amount of material in the tub, and how the hammer strikes the object.

Figure 1.2





The amount of material in the tub can dampen or stop the object's potential flight. Keeping the tub full will reduce the risks. Filling the tub at least 1/2 full before engaging tub rotation will reduce the risk. Using a geyser plate can help reduce thrown objects. A risk may arise when the tub is being emptied, such as at the end of the grind. Running the engine at slower speeds when starting or finishing the grind will also help, especially slowing down when emptying the tub. Keeping the tub covered with DuraTech Industries Tub Covers will also reduce the risk of potential injury or property damage. Use of a Tub Cover will not reduce the area over which thrown objects may fall, but it does reduce the percentage of objects thrown from the tub.



**WARNING:** To minimize the potential risk of injury or property damage, the operator must:

- a) Place side B towards open areas, away from property and people.
- b) Load the grinder from side A with a loader equipped with an enclosed cab.
- c) Keep observers and unauthorized personnel out of the area.
- d) Wear a hard hat, safety glasses, and ear protection at a minimum, and require that any other persons in the area are similarly equipped.
- e) If the optional tub cover is installed on the machine, the operator should keep the Tub Cover over the tub as much as possible while grinding. While grinding, the Tub Cover should be raised only when adding material to the tub, and then the Tub Cover should only be raised enough to allow the new materials to be placed in the tub.

## 1.7 Service and maintenance (REV. 06-14)



**CAUTION:** The stored up energy in the rotor causes it to rotate long after the clutch has been disengaged. Before performing any maintenance on the machine or getting into the tub, be sure rotor and all moving parts have come to a complete stop. Shut off engine and remove the key.

Before working on or near the Tub Grinder for any reason such as servicing, inspecting or unclogging the machine:

- Follow the normal shutdown procedure found on page 25 of this manual.
- If the unit is still attached to a towing vehicle, place the towing vehicle's transmission in park and set the parking/emergency brake.
- Relieve all pressure in the hydraulic system before disconnecting hydraulic lines or performing work on the system. Make sure all connections are tight and the hoses and lines are in good condition before applying pressure to the system.



**WARNING:** Hydraulic fluid escaping under pressure can be invisible and have enough force to penetrate the skin. When searching for a suspected leak, use a piece of wood or a cardboard rather than your hands. If injured, seek medical attention immediately to prevent serious infection or reaction.



When replacing any part on your Tub Grinder, be sure to use only DuraTech Industries authorized parts.



**DO NOT PERFORM MAINTENANCE ON THE INTERIOR OF THE TUB DURING WET WEATHER CONDITIONS**

## 1.8 Personal protection equipment (REV. 01-03)

Operators and authorized observers of the Tub Grinder are recommended to wear head, eye, and ear protection. No loose clothing is allowed.

## 1.9 Fire Prevention (REV. 06-14)

Grinding with a tub grinder produces a large amount of potentially combustible material. The risks of fire can be significantly reduced with proper operating and maintenance procedures. This does include frequent removal of dust, debris, and other combustible materials.

Most of the products that are ground are dry and the grinding process can produce fine, dusty material. The grinding process can produce heat and the spinning rotor will circulate air within the grinding chamber. For a fire to start, fuel, oxygen and heat in sufficient quantity, must be present. During normal operation and with a properly maintained tub grinder, the material being ground will move through the grinding chamber so quickly that it doesn't have a chance to heat up sufficiently to start a fire. Also, the rapid rate that a tub grinder can pile material will quickly smother small hot spots that might occur during normal grinding operations. Keeping the material moving through the machine and across the top of the rotor is important to keep frictional heating of the material to a minimum.



**NO SMOKING IN THIS AREA**



**DANGER! NO OPEN FLAMES IN THIS AREA**



**IMPORTANT: NEVER** leave the vicinity of the unit with the engine running.

### PROPER OPERATION OF THE TUB GRINDER:

- Do not grind materials any finer than necessary. Finely ground materials will produce more dust and increase the risk of fire. If finely ground materials are required, it is better to grind the materials coarse first with large opening screens installed in the grinder and then regrind them to the desired consistency by installing smaller opening screens in the grinder. Be especially cautious when grinding materials that can burn easily.
- When filling the tub grinder during start-up begin by filling the front of the tub and avoid placing materials on the spinning rotor. When material begins to fall over the rotor, set the governor control on "Manual" and rotate the tub slowly while continuing to fill the tub. When the tub is 1/2 to 2/3 full, the governor control can be set to "auto" and grinding operations can resume normally. Do not allow the tub to stop for any significant amount of time with material over the rotor to minimize frictional heating.
- Do not smoke when working with combustible materials.



## REMOVAL AND CLEANING INSTRUCTIONS:

- Clean the engine compartment daily or more often if conditions require it be done more frequently. When cleaning the engine compartment, always clean the top of the engine and the areas around exhaust manifolds, exhaust plumbing and turbochargers.
- Check the rotor box for debris built up around the rotor. Remove material that may be packed tight near the bearings, on shaft or other rotating components because it will become hot due to friction.
- At shutdown, always clean and remove all dust, debris, or combustible material off the entire grinder. Use high-pressure air or water if necessary. Always move the grinder and all other equipment away from the ground material pile before leaving the job site in case of smoldering combustion in the ground material.

## TUB GRINDER MAINTENANCE:

- Repair any fuel or hydraulic leaks as quickly as they are discovered. Clean up spills immediately. Fuel or oil soaked materials can contribute significantly to the rapid spreading of a fire once it has begun.
- Inspect all electrical wiring periodically. Any chafed or damaged wires should be repaired immediately. Keep all electrical connections tight to prevent arcs or sparks.
- Contact between the rotor and any stationary component of the grinding chamber such as contact between the hammers and the screens must be corrected immediately.



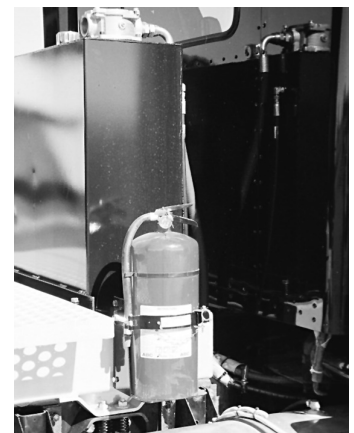
## 1.10 Fire Extinguishers (REV. 01-03)

Fire extinguishers are provided on these DuraTech grinders in the unlikely event that a fire does start on the grinder. An extinguisher is located on both sides of the machine near the front hydraulic reservoir. The extinguishers are ABC dry chemical extinguishers that are appropriate for use with all materials normally encountered on a tub grinder.

If a fire does start, CALL THE LOCAL FIRE DEPARTMENT IMMEDIATELY. Then, use the fire extinguisher if you feel confident that you can extinguish the fire. A 10# extinguisher will last about 15-20 seconds and a 20# extinguisher will last about 20-24 seconds, so they will not stop a large fire.

**When using a fire extinguisher, use the PASS method:**

- Approach the fire with the wind at your back.
- Pull the pin,
- Aim the spout,
- Squeeze the trigger, and
- Sweep along the base of the fire from about 6-8 feet away.



fire extinguisher location





Read the label on your extinguisher now, most extinguishers have descriptions of this method, and an estimated working time.

If an extinguisher is only partially used, the dry chemical will jam in the seals, allowing the extinguisher to lose its pressure charge in less than an hour, making it useless to you. It must be recharged before placing it back on the machine. Have the extinguisher recharged today; a fire will not wait for you to recharge your extinguisher tomorrow!

Fire extinguishers should be inspected and recharged by a professional at least annually to keep them at optimum performance! A “verification of service” collar that confirms the month and year of service should be attached to the neck of the container to confirm when the extinguisher was last serviced.

## 1.11 Important safety reminders (REV. 01-03)

Always follow basic safety precautions when using this unit to reduce the risk of injury.



**IMPORTANT: NEVER** perform maintenance in the tub, under the machine, on the conveyor, or other moving part of the machine without first shutting off the engine and removing the key.

Unauthorized personnel should stay out of the grinding area. Flying debris can injure inattentive personnel.



**IMPORTANT: NEVER** climb on the machine, crawl under the machine, or enter the tub when the engine is running or the machine is in operation.

## 1.12 Towing (REV. 01-03)

Check all lights, brakes and hitch connections before towing. Check your state laws regarding the use of lights, safety chains, moving wide loads on public roads, and other possible requirements.

Use caution when traveling on public roads, rough or winding roads, or steep terrain.

See Section 3.23 for more information about preparing the unit for transport.



## Section 2: Introduction

### 2.1 Description of the 3010 DuraTech Tub Grinders (REV. 01-03)

The Tub Grinder is designed to grind wood waste, green waste, construction and demolition debris, tree branches and trunks, compostables and mulch. The unit incorporates a number of basic features including the engine, electronic engine controls, rotating tub, the electronic governor, the rotor and hammer assemblies, the tub chain and drive assemblies, as well as the belly and discharge conveyors assemblies.

Material is fed into the tub of the unit by appropriate means, such as a wheel loader. As the tub rotates, the material is exposed to the rotating hammers. The hammers then grind the material before the material is discharged by the belly and discharge conveyors.

### 2.2 Electronic governor (REV. 01-03)

The Model RCB93 Electronic Governor regulates the speed at which the tub rotates. The electronic governor has two modes of operation, the Engine (Auto) mode and the Tub (Manual) mode. The Engine (Auto) mode is the preferred mode of operation and should be used whenever possible.



**IMPORTANT:** Except when calibrating or trouble shooting the electronic governor always use the Engine (Auto) mode of the electronic governor.

#### Engine (Auto) Mode

When the electronic governor is switched to the Engine (Auto) mode, it is monitoring the rotation speed of the engine. The hydraulic flow to the tub drive mechanism is regulated proportionally to the engine speed. When the engine begins to lug down, the hydraulic oil flow is reduced which in turn slows down the tub rotation. With proper calibration, the engine will only lug down to its optimum horsepower RPM and the tub rotation will be varied proportionally to keep the engine at this RPM. The result is a nearly constant load on the engine, which will maximize grinding efficiency. **See section 3.10 (pg. 32) for calibration instructions.**

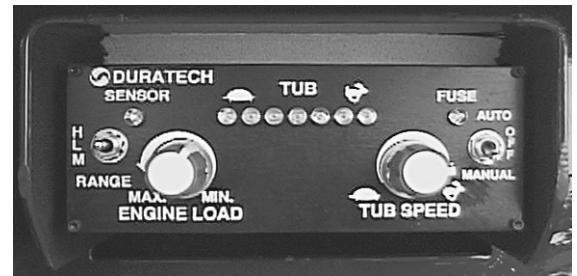
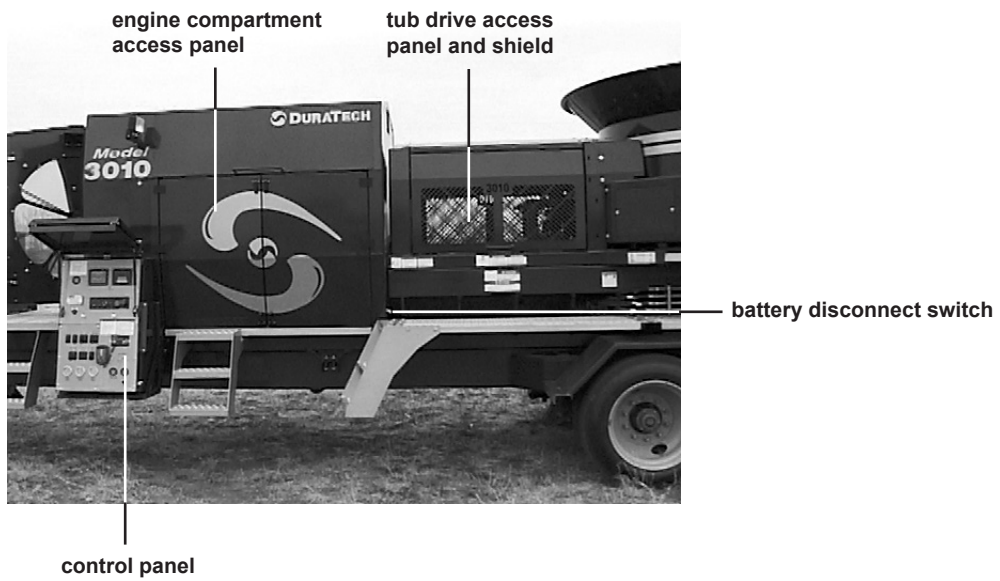
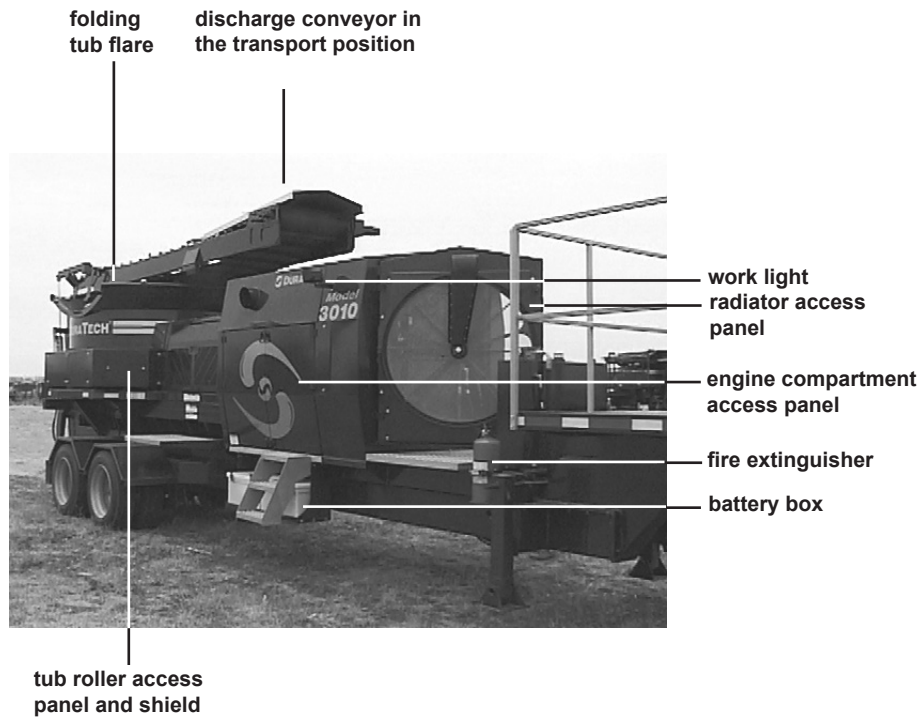


figure 2.1 model RCB93 electronic governor



figures 2.2 & 2.3  
major system components





## 2.3 Wet clutch (REV. 04--03)

The HPTO Hydraulic Power Take-off is a totally enclosed wet hydraulic clutch that requires no adjustment throughout its wear life. During a torque spike, the wet clutch will act as a torque limiter by slipping to absorb the shock load.

The controller contains the preprogrammed settings for how the HPTO will function during startup. The “Power” LED will illuminate when power is received from the ignition switch. Note that power is off when the tub is raised. This prevents the operator from spinning the rotor while the tub is raised.

The “Engine Speed Detected” LED illuminates when the engine is spinning.

To engage the wet clutch, set engine speed below 1100 RPM, and press the Clutch Start Button for 3 seconds (the blue beacon light should be lit during this time). When the “Clutch Engaged” symbol illuminates, the start button can be released. The controller will “bump” the wet clutch several times while bringing the rotor up to speed.

If the engine speed is above 1100 RPM, the “RPM Too High” symbol will illuminate, and the wet clutch will not engage. Reduce engine speed below 1100 rpm and try again.

To disengage the wet clutch, press the Clutch Start Button. If engine speed is above 1200 RPM, the “RPM Too High” symbol will illuminate. Reduce engine speed below 1200 RPM and try again.

The controller will allow 3 starts in 5 minutes. If a 4<sup>th</sup> start is attempted, the “Timed Lockout” symbol will illuminate, and the wet clutch will not engage for 10 minutes.

The blue beacon light will flash during startup, and during some fault conditions. If the oil gets too hot, the light will flash, the “Oil Temperature” symbol will illuminate, but the wet clutch will stay engaged. The operator must disengage the wet clutch, and allow the system to cool off. With a plugged oil filter, the “Filter Clogged” symbol will illuminate. The operator must disengage the wet clutch, shut the engine off, and change the filter (4400073).

The wet clutch will disengage when there is an oil pressure fault, or when the engine speed signal is lost.

## 2.4 Rotor (REV.. 04-03)

The rotor is the heart of the grinder. The standard rotor contains fixed hammers and is used for general grinding. Swinging hammers are available for use when grinding debris contaminated with tramp metal.

## 2.5 Screens (REV. 01-03)

All DuraTech Industries tub grinders come equipped from the factory with two screens. The diameter of the screens are specified by the customer at the time of purchase.

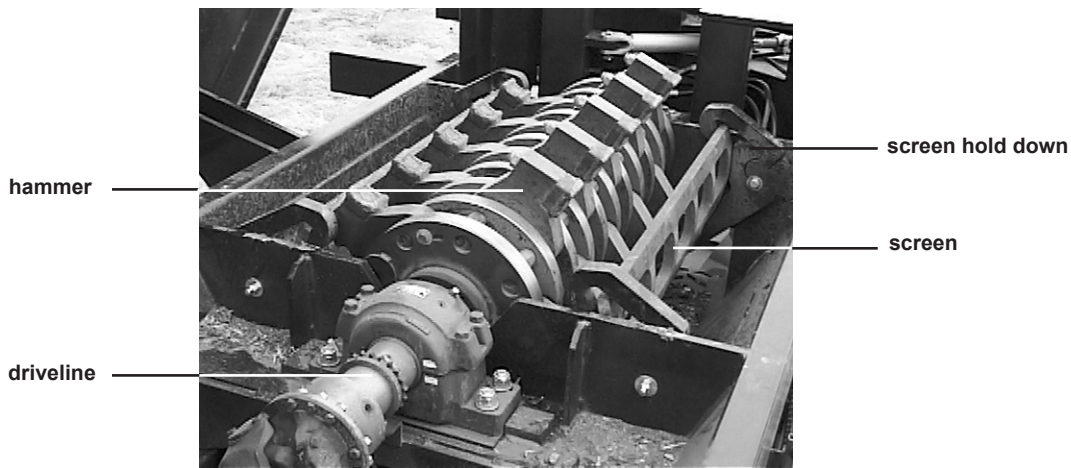
Any combination of hole sizes may be used to alter the coarseness of the output material. The coarseness of the ground material is determined by the size of the screen holes. As the size of the screen holes becomes larger, the coarseness of the ground material increases.

Round perforated screens are available with 1-1/2”, 2”, 3”, 4”, & 5” round hole, and 6”x 7” demolition screen. The 1-1/2” screen is made from 1/2” thick Hardox material; all other screens are 1” thick steel.

**Note:** If a combination of screens with different hole diameters are used, the screen with the smallest hole diameter is normally placed on the down swing side of rotor.



**figure 2.4**  
driveline, rotor, and screens



## **2.6 Tub** (REV. 01-03)

Material to be ground is loaded into the tub using a wheel loader, or other suitable method. As the tub rotates, this material is fed to the rotor. The faster the tub rotates, the more material is exposed to the rotor, and the greater the load on the engine. The tub's rotation speed is controlled by the electronic governor. To reduce the amount of material thrown from the tub during operation, the tub should be kept 1/2 to completely full.

The 3010 DURATECH TUB GRINDER's tub can be tilted 90 degrees for access to the rotor, screens, and drive line. The tub has an electronic safety switch that will not allow the tub to be raised with the rotor turning. The switch provides feedback to the operator through two indicator lights which are located on the control panel. If the green indicator light is on, the operator may tilt the tub. Conversely, if the red indicator light is on, the safety switch will prevent the operator from tilting the tub.

## **2.7 Hydraulic cooler** (REV. 01-03)

The hydraulic system has a radiator to disperse excess heat. It is mounted in front of the engine radiator, and can be accessed via the radiator access panel.

## **2.8 Wet clutch cooler** (REV. 01-03)

The hydraulic clutch system has a radiator to dissipate excess heat. It is mounted in front of the engine radiator, and can be accessed via the radiator access panel.

## **2.9 The conveyor system** (REV. 01-03)

The conveyor system on the 3010 DURATECH TUB GRINDER consists of a belly conveyor and a discharge conveyor. The belly conveyor transfers the ground material from the rotor to the discharge conveyor. The discharge conveyor then moves the material away from the unit. The conveyors are run by two hydraulic orbit motors which are turned on and off with one control switch. This switch is located at the control panel. The discharge conveyor can be raised or lowered from the control panel. The discharge conveyor can also be swung left or right using the controls on the control panel. The discharge conveyor can also be folded for transport from the conveyor controls located on the control panel.





## 2.10 Tub cover (optional) (REV. 04-11)

An optional tub cover may be added to the unit that helps to reduce the amount of material ejected from the tub while grinding. Duratech recommends using a tub cover when grinding in a high traffic area.

## 2.11 Control panel (REV. 06-14)

figure 2.5  
top control panel  
(Cat panel tier II)

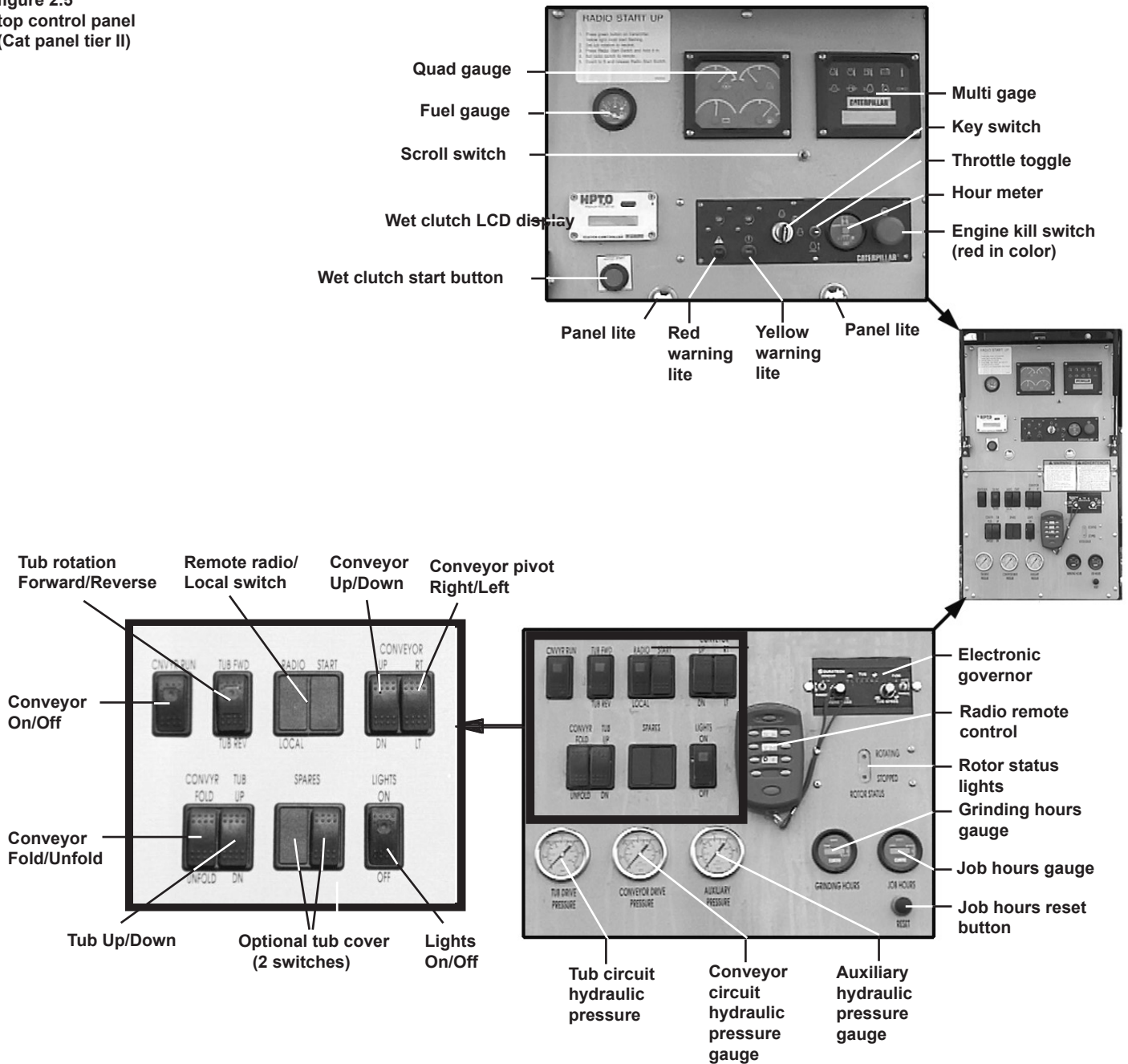




figure 2.6  
top control panel  
(Cat panel tier III)  
(S.N. Up to 3129)

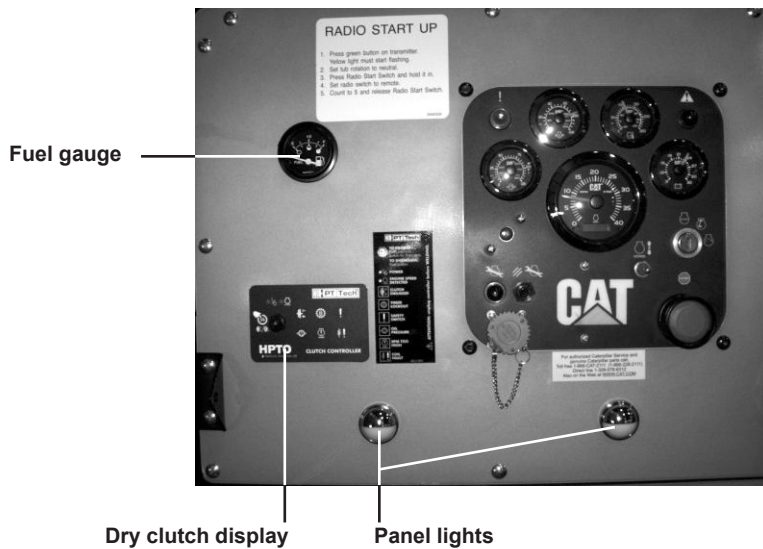


figure 2.7  
Cat control panel for tier III engines



The control panel is located on the left hand side of the engine. Controls on the control panel include; engine start, emergency kill switch, throttle, tub controls, conveyor on/off, conveyor positioning, rotor engage button, rotor disengage button, tub governor, tub tilt, and the job hours reset button.

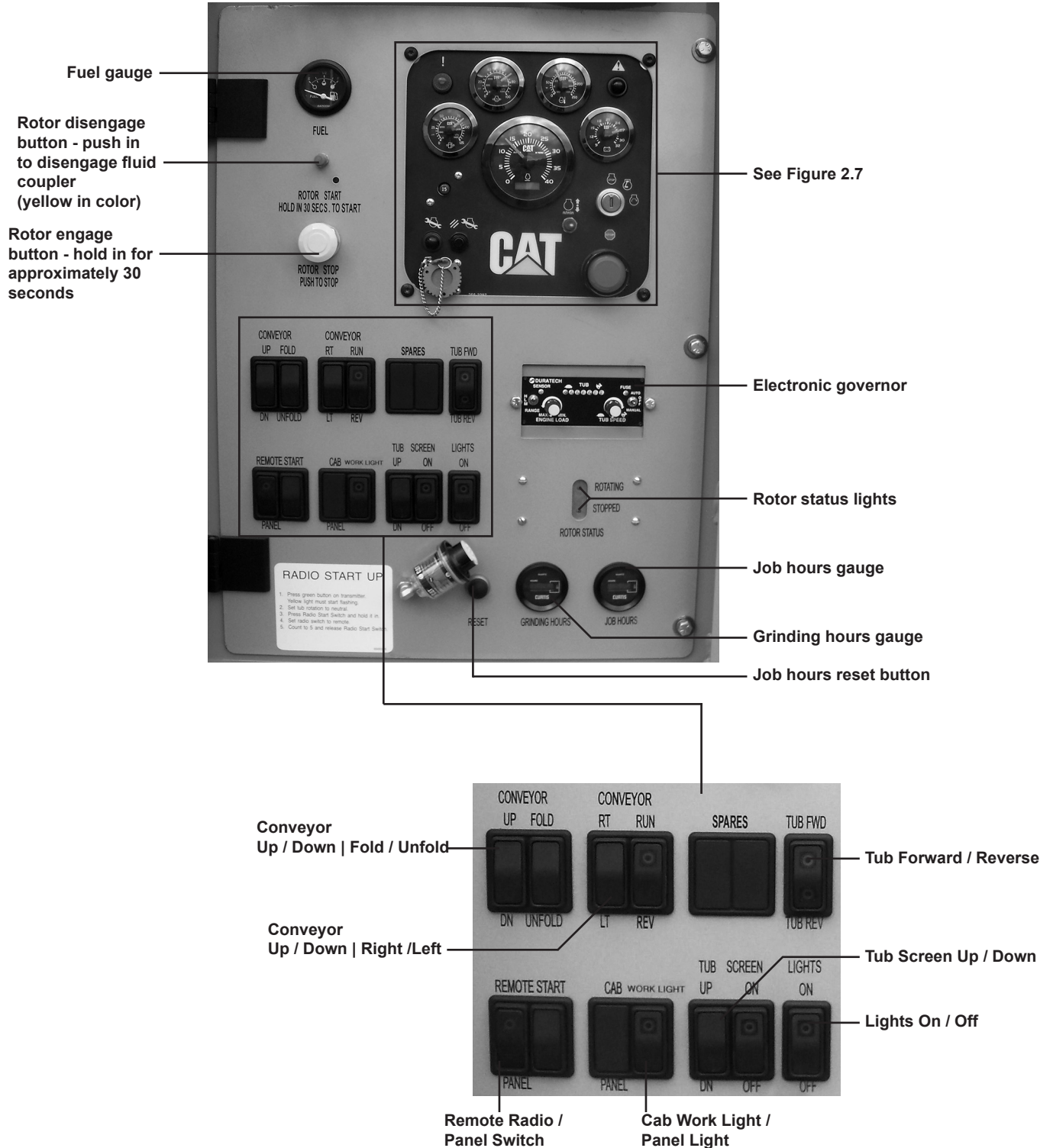
Gauges on the control panel include; tub circuit hydraulic pressure, conveyor hydraulic pressure, auxiliary hydraulic pressure, fuel level, grinding hours gauge, job hours gauge, and a quad gauge with engine oil pressure, battery, engine temperature and fuel level, and a multi gauge.





## 2.11b Control panel (S.N. 3130 And Up) (REV. 06-14)

figure 2.8  
control panel  
(CAT Panel Tier III)





## 2.12 Other controls (REV. 01-03)

### Radio remote control unit (optional)

The optional radio remote control unit allows the operator to remotely start and stop the tub, change the tub's direction of rotation to forward or reverse, perform an emergency stop, raise and lower the conveyor, swing the conveyor left and right, and operate the throttle.



**NOTE:** See also section 3.17, "Operating the grinder using the remote radio option."

### Battery disconnect switch

The battery disconnect switch is used to connect and disconnect the main battery cable to the machine. When the machine is not in use, it should be disconnected.

battery disconnect switch





## Section 3: Operation

### 3.1 Pre-operation inspection (REV. 01-03)

Read and have a thorough understanding of the operator's manual, especially the sections pertaining to machine operation and safety. Also make sure that anyone who will assist you in the operation or maintenance of this machine understands how the machine operates.

Before operating the 3010 DuraTech Tub Grinder, perform an inspection that includes the following items. As each task is performed, check or initial the adjacent box.

- Check lubrication points and lubricate as recommended in the general maintenance section of this manual.
- Make sure that the machine is properly adjusted. Procedures for making adjustments to various 3010 DURATECH TUB GRINDER components can be found later in this section.
- Check engines oil level and coolant level, and add or change as necessary. Also look for oil or coolant leaks and repair as necessary.
- Check the hydraulic oil level, and add or change the hydraulic oil as necessary. Also look for leaks in the hydraulic system.
- Check the air cleaner service indicator. If the red indicator is visible, service the air cleaner.
- Check for buildup of debris around the radiator, turbocharger, manifolds, air intake and moving parts. Remove the debris before operating the unit.
- Inspect belts for cracks, breaks, or other damage.
- Inspect wiring for loose connections and for worn or frayed wires.
- Check the fuel supply, and drain any water from the water separator.
- Visually examine the rotor to see if any parts show excessive wear. These parts include shaft, plates, rods, hammers and movable plate. Replace or repair any worn parts before operating the unit.
- Check the screens for wear. Also check the screen hold downs for wear and tightness. Replace or repair any worn parts before operating the unit.
- Visually examine the rotor bearings and the mounting bolts and check all bearings for wear. Replace or repair any worn parts before operating the unit.
- Make sure that all shields and guards are in place and in operating condition.
- Check clutch oil level.
- Check rotor bearing oil level.
- Check pressure rollers for proper bearing adjustment.



## 3.2 Starting the Tub Grinder (REV. 01-03)



**NOTE:** The engine will start easier at cool temperatures by use of a starting aid. A block heater or other means can be used to warm the engine.

**NOTE:** Do not crank the engine for more than 30 seconds. Allow the starter motor to cool for two minutes before cranking again.

Check engine manufacturers recommendations for starting the engine, and follow their recommendations where applicable.

Check for **DO NOT OPERATE** or similar warning tags. Do not move any controls if such tags are on the machine.

To start the engine, perform the following steps:

1. Perform the pre-operation inspection.
2. Turn the battery disconnect switch to “ON”.
3. Shout the word “**CLEAR**”.
4. Turn the key to the start position and release it when the engine starts.
5. If the oil pressure does not rise within ten seconds after starting, stop the engine and make the necessary repairs.
6. Reduce the engine speed to a low idle. Allow the engine to idle for 3 to 5 minutes, or until the water temperature gauge indicator has begun to rise. The engine should run smoothly at low idle.
7. Make another walk-around inspection checking the engine and hydraulic system for fluid leaks.
8. Follow the engine manufacturers recommendations for the care and maintenance of a new engine.



**NOTE:** See also section 3.17, “Operating the grinder using the remote radio option”

## 3.3 If the engine fails to start (REV. 01-03)

If the engine doesn't start on the first try, perform the following steps:

1. Wait two minutes before attempting to restart.
2. Shout the word “**CLEAR**”.
3. Do not run the starter for more than 30 seconds.
4. If the engine fails to start, contact a qualified diesel mechanic for further advice.

## 3.4 Throttle operation (REV. 01-03)

To increase throttle speed push and hold the throttle switch up.

To decrease throttle speed, push and hold the throttle switch down.



### 3.5 Automatic engine shutdown system (REV. 01-03)

The engine will automatically shut down if it overheats or if engine oil pressure is inadequate. If this happens, perform the following steps:

1. Check the engine oil level.
2. Inspect the radiator, rotating screen, and clean if necessary.
3. Check tension and condition of the fan and rotating screen belts.
4. Allow engine to cool and check the coolant level.
5. Attempt to restart engine following the normal starting procedure.
6. If the engine will not continue running, contact a qualified mechanic.

### 3.6 Normal shutdown procedure (REV. 01-03)



**NOTE:** Stopping the engine immediately after it has been working under load can result in overheating and accelerated wear of the engine components. Allow the engine to cool down before stopping. Avoiding hot engine shutdowns will maximize turbocharger, shaft, and bearing life.

Use the following procedure to shut down the Tub Grinder under normal operation:

1. Disengage the tub drive.
2. Allow the conveyor belts to run until empty.
3. Lower engine rpm to idle, and disengage the wet clutch by pressing the rotor disengage button on the control panel.
4. After the rotor has stopped, disengage the conveyor drive.
5. Follow the engine manufacturer's recommendations for cooling the engine; generally, this consists of running the engine at 1/2 speed or idle for 5 minutes.
6. Shut off the engine and remove the key.
7. Turn the battery disconnect switch to "OFF".
8. Note the service hour meter reading, and perform periodic maintenance as required.
9. Repair any leaks, perform minor adjustments, tighten loose bolts, etc.

**NOTE:** See also section 3.17, "Operating the grinder using the remote radio option"

### 3.7 Emergency shutdown procedure (REV. 01-03)



**IMPORTANT:** Emergency shutoff controls are for **EMERGENCY** use Only. **DO NOT** use the emergency shutoff controls for normal stopping procedure.

**NOTE:** The emergency stop button will have to be reset before restarting the engine.

1. Push in emergency stop button located on the control panel (large red button), and remove key.

**NOTE:** See also section 3.17, "Operating the grinder using the remote radio option"



## **3.8 Parts of the electronic governor**

(REV. 01-03)

### **FUSE LIGHT**

This light is on when the key switch is receiving power.

### **SENSOR LIGHT**

This light is on whenever the electronic governor is receiving an adequate input signal from the sensor. For the sensor light to work you must:

- Have the fluid clutch engaged.
- The engine running at grinding RPM.
- The Mode Switch must be switched to the engine (auto) or manual position.

### **SPEED LIGHTS**

These lights provide a relative indication of how fast your tub should be turning based on the output signal that the electronic governor is sending to the electro-hydraulic valve when in engine (auto) mode.

### **MODE SWITCH**

The mode switch has three possible positions.

The off position which turns the electronic governor off and two other positions which correspond to the tub (manual) and engine (auto) modes of operation.

In the “tub (manual)” position the tub will rotate at a constant speed based on the settings of the Tub Limit Knob (Tub Speed Knob).

The “engine (auto)” position uses all the functions of the Electronic Governor. The maximum tub speed will be limited by the Tub Limit Knob (Tub Speed Knob), and the engine load will be controlled by the Engine Load Knob.

### **TUB LIMIT KNOB (TUB SPEED KNOB)**

This knob sets the maximum speed at which the tub will rotate in both the tub (manual) and engine (auto) modes. In the engine (auto) mode tub speed will vary between zero and this setting depending on the engine load.

### **ENGINE LOAD KNOB**

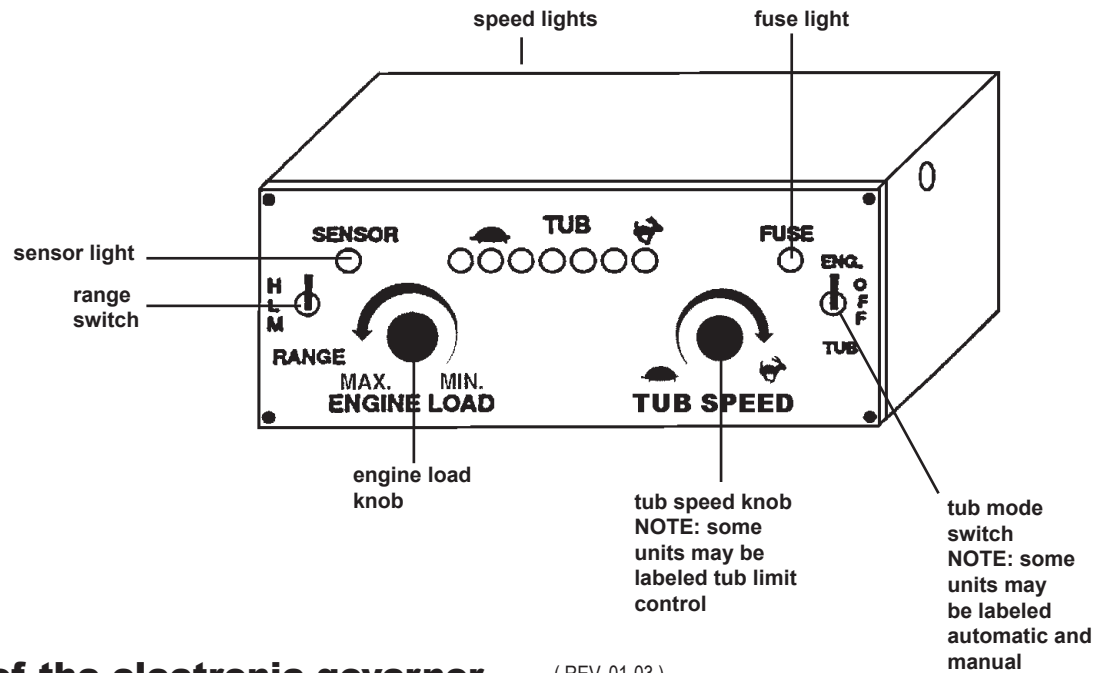
This knob is used only in engine (auto) mode. It controls the load placed on the engine. Turning the knob clockwise decreases engine load, and turning the knob counterclockwise increases the engine load.

### **RANGE SWITCH**

This switch is a coarse adjustment for the engine load knob and can be switched to a H- high, M-medium or L-low setting.



figure 3.1  
electronic governor  
controls



### 3.9 Operation of the electronic governor

(REV. 01-03)

#### Engine (Auto) mode



**IMPORTANT:** Except when calibrating or trouble shooting the electronic governor always use the engine (auto) mode of the electronic governor.

In engine (auto) mode, the electronic governor monitors the rotation speed of the engine. The hydraulic flow to the tub drive mechanism is regulated in proportion to the engine speed. As the engine speed slows, the electronic governor decreases the hydraulic flow which slows down the tub's rotation. Conversely, as the engine speed increases, the electronic governor increases the hydraulic flow which speeds up the tub's rotation. This allows the electronic governor to automatically control the feed rate keeping the engine running within the governor's optimum power zone. When the load on the grinding rotor begins to lug the engine, the governor automatically reduces the tub's rotation speed in proportion to the load. The result is nearly a constant load on the engine, which maximizes the grinding efficiency.

The range of rotor speeds for which the electronic governor will regulate the hydraulic flow is determined by the setting of the engine load knob. For example, turning the engine load knob counter clockwise will increase the load on the engine by keeping the tub engaged to a lower engine RPM.

With proper calibration, the engine will only load down to its optimum horsepower RPM, and the tub's rotation speed will be varied proportionally to keep the engine at this RPM.

#### Tub (Manual) mode

In tub (manual) mode, the electronic governor performs as a simple tub speed control. In this mode the tub speed is constant and it will not change to match varying load conditions.





### 3.10 Calibration of the electronic governor

(REV. 01-03)

To calibrate the electronic governor, perform the following steps:

1. Begin calibration procedure with 3010 DURATECH TUB GRINDER Tub Grinder completely shutdown. Place the MODE switch in the OFF position and the RANGE switch in the H-High position. Rotate the TUB SPEED KNOB fully clockwise toward the rabbit position. Turn the ENGINE LOAD KNOB fully clockwise, and switch the MODE switch to ENGINE (Auto) Position.
2. Verify that wet clutch is disengaged. Inspect machine to verify that all personnel are clear of the machine.
3. Start engine and run the grinder at about 1/2 throttle to allow the hydraulic system to warm up before calibrating the RCB93 Electronic Governor.
4. When the system has reached operating temperature, throttle the engine to between 900 & 1100 RPM. Engage the rotor and tub drive then throttle up to 1800 RPM. The FUSE light and the SENSOR light should come on. The tub should not be rotating at this time. If the tub is rotating, read section 6.1 “Troubleshooting the electronic governor system” in this manual.
5. Slowly rotate the ENGINE LOAD KNOB counter-clockwise until the tub just begins to move. The tub should begin to rotate. If it does not begin to rotate, switch the range switch to M-Medium or L-Low and repeat as necessary.

**TEST:** Throttle the engine down and the tub should stop rotating, return the engine to 1800 RPM and the tub should start to rotate.

If the tub will not rotate, read section 6.1 “Troubleshooting the electronic governor system” in this manual.

### 3.11 Adjusting the tub’s rotation speed

(REV. 01-03)

Tub rotation is controlled by two components or remote radio. The tub is started, stopped and reversed by a switch on the control panel or the remote radio control and the tub’s rotation speed is controlled by the tub limit knob (tub speed knob) on the electronic governor.

### 3.12 Raising the tub (REV. 01-03)



**NOTE:** If the grinder becomes plugged or if the rotor requires maintenance, do not raise the platform with the tub full of material.

To raise the tub, perform the following steps:

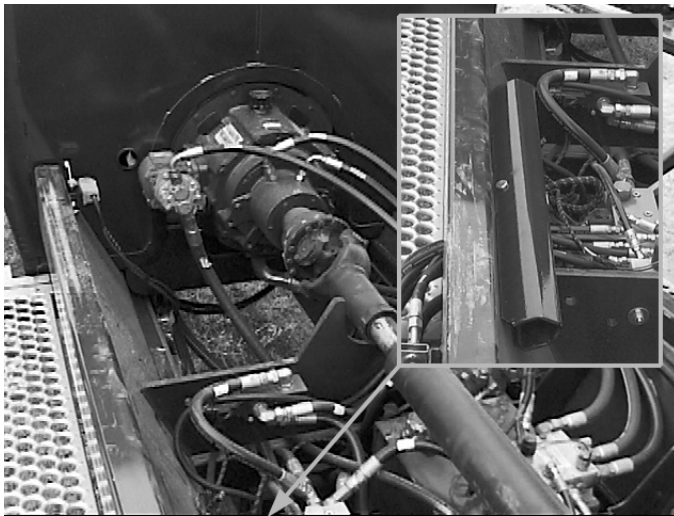
1. Verify that the tub grinder is parked on level surface.
2. Disengage the clutch, and wait for the rotor to stop turning.
3. If your machine is equipped with a tub cover place tub cover in fully closed position
4. As material in the tub may roll some distance, make sure the area on the right hand side of machine is clear of personnel and equipment. Shout the word “**CLEAR**”.



5. The engine speed should be 1000 RPM.
6. Operate the tub tilt switch on the control panel to raise the tub. If the red tub interlock indicator on the operator station control panel is lit, the tub will not raise. If the green tub interlock indicator on the operator station control panel is lit, the tub may be raised.
7. Raise the tub fully, and install the safety stop on the hydraulic cylinder. The safety stop is located in its storage location on the inside of frame rail.



**NOTE:** The tub will not lift if the rotor is turning. Also, when the tub is raised, the clutch will not engage. If the tub is full of material, the hydraulic cylinder will not raise the tub.



### 3.13 Lowering the tub (REV. 01-03)

To lower the tub, perform the following steps:

1. Remove the safety stop on the hydraulic cylinder, and place safety stop in storage location on the inside of frame rail.
2. Clear the area of equipment and personnel.
3. Engine speed should be 1000 RPM.
4. Operate the tub tilt switch on the control panel to lower the tub.



### 3.14 Starting and stopping the belly and discharge conveyors (REV. 01-03)

The belly and discharge conveyors are on one circuit, so one control starts and stops both conveyors. The control is found at the operator panel near the engine. Conveyors should be started before the rotor is started, and should be allowed to run until the rotor stops turning.

**NOTE:** See also section 3.17, “Operating the grinder using the remote radio option”

### 3.15 Lifting the discharge conveyor (REV. 01-03)

The discharge conveyor can be raised or lowered as needed. There is one set of controls for raising and lowering the conveyor located in the operator panel.

**NOTE:** See also section 3.17, “Operating the grinder using the remote radio option”

### 3.16 Pivoting the discharge conveyor (REV. 01-03)

The conveyor can be swung left or right as needed by controls located in the control panel.



**NOTE:** The conveyor controls are set in reference to machine left and machine right.



**CAUTION:** Make sure that no one is between the conveyor and the main frame before pivoting the conveyor.

**NOTE:** See also section 3.17, “Operating the grinder using the remote radio option”



### 3.17 Operating the grinder using the remote radio option

(REV. 01-03)

#### Using the Omnex Origa remote radio transmitter

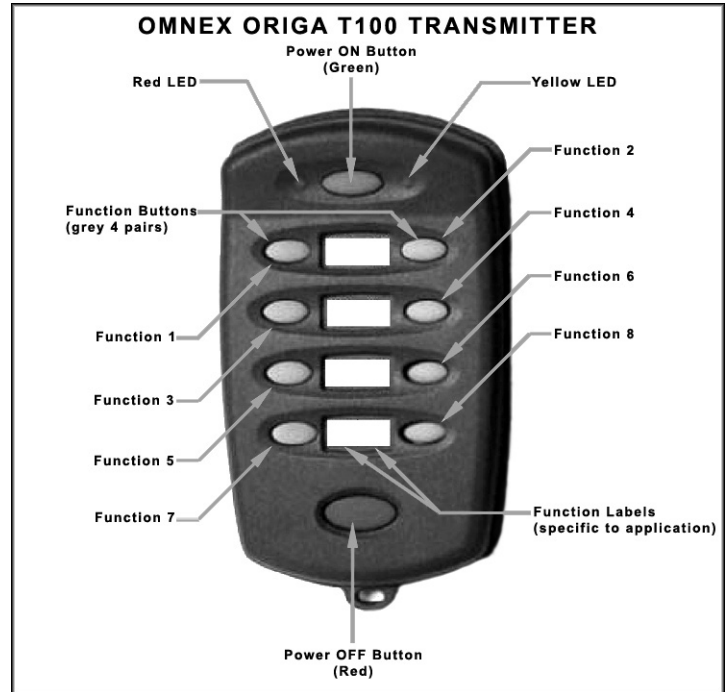
The Remote/Local switch located on the control panel will switch from manual to remote control. Switch to remote when remote control is desired.

The transmitter will stop the engine, start, stop and reverse the tub, and raise, lower, and swing the conveyor.

#### LED indicators

The yellow LED indicator is located on the upper right hand side of the radio transmitter. This LED indicates that the controller is powered up and transmitting. Light may be solid or flashing depending on mode. During normal operation this LED is flashing.

The red LED indicator is located on the upper left hand side of the radio transmitter. This LED flashes slowly to indicate the transmitter has less than twenty percent of battery capacity remaining.



When both the red and yellow LEDs are on, the transmitter is in configuration/program mode.

#### Mode of operation

The Omnex Origa system has several modes of operation. The mode preset for DuraTech Industries is:

1. The Power ON (green) button powers up the transmitter. Output 9 on the receiver is energized when the Power ON button is pressed. (see diagrams in section 6.3, on page 93)
2. All functions are shut off when the Power OFF button (red button) is pressed. When the radio is restarted, all functions will be off. The transmitter will stay on until the Power OFF button is pressed.



**NOTE:** The engine will also be shut off when the Power OFF button is pressed and the remote/local switch is set on radio.



3. Output 10 on the receiver is energized when any of functions 3-8 are pressed.
4. Functions 1 & 2 are interlocked latched functions and are used for tub rotation. Pressing one function will start that function. It will not stop until either button is pressed. There is a two second delay when changing tub direction.
5. Functions 3-8 are interlocked momentary functions. These are used for momentary functions. These functions are energized only when the buttons are pressed. Functions 3 and 4 are used for the throttle. Functions 5 and 6 are used to lift and swing the conveyor. If the tub cover option is on the grinder, extra functions (tub cover in/out and up/down) are possible when pressing the “on” button and the function button at the same time.

For more information on using and troubleshooting the Omnex Origa system, please refer to Section 6.3, “Troubleshooting the Omnex Wireless Remote Controls which starts on page 97.

### **Remote radio start up**

To begin using the remote radio, perform the following steps:

1. Press the green (power on) button on the transmitter. The yellow LED should start flashing to indicate that the transmitter is transmitting.
2. Set tub rotation to neutral on the machine’s control panel.
3. Press the Radio start switch on the control panel and hold it in.
4. Set the radio switch on the control panel to “REMOTE”.
5. Count to 5 and release the Radio start switch.

### **Radio shutdown (switching back to local)**

1. Set the radio switch on the control panel to “LOCAL”.
2. Press red button on the transmitter, and set the in the storage location on the control panel.



### 3.18 Grinding (REV. 01-03)

Before you begin grinding, start the machine and check the direction of the tub's rotation. Also check the electronic governor for proper operation.

Watch for unusual or excessive vibration. If any occur, immediately shut off the power. Determine the cause and correct it before starting the grinder again.

In cold weather, warm up the machine for five minutes before grinding.

To begin grinding, perform the following steps:

1. Start the engine as described in "Starting the Grinder."
2. Unfold the discharge conveyor and set it to the desired height.
3. Engage the conveyor run switch to the forward position.
4. Engage the wet clutch by pressing the clutch start button in, and holding it in until the LCD Display changes to "Clutch engaging".

### 3.19 Grinding with tub cover (REV. 01-03)

The Tub Cover is designed to deflect most objects thrown out of an Tub Grinder. The movable top cover does the deflecting, and the closer it is set to the tub, the more debris it will deflect. The Tub Cover can be rotated up and down, and the support frame can be rotated in towards the tub or out away from the tub. During normal grinding, keep the tub cover as close to the tub as practical. When emptying the tub, close the tub cover until it almost contacts the tub, providing coverage of most of the tub, and stopping most of the debris as the tub empties out.

### 3.20 Loading the tub (REV. 01-03)



**IMPORTANT:** Never drop a large object or objects into the tub from a high level. Ease the material over the edge and down into the tub carefully.

Material to be ground should be placed directly into the tub. The best method for filling the tub is:

1. Engage the rotor as described above.
2. Fill the tub about halfway full of unground material before starting tub rotation.
3. Start tub in the forward direction by switching the electronic governor Engine(Auto) mode and switching tub direction to forward.
4. Place additional materials in the tub as needed.





### 3.21 If lodging occurs while grinding (REV. 01-03)

Occasionally materials may lodge against the side of the tub and not feed down to the mill. If this occurs, reverse the tub direction briefly, and then start the tub in a forward direction again. This practice normally dislodges any materials.



**CAUTION:** Never attempt to dislodge material inside the tub when machine is in operation by manually pushing materials down. **TO PREVENT SERIOUS INJURY OR DEATH, STAY OUT OF THE TUB WHEN THE MACHINE IS IN OPERATION!**

### 3.22 Grinding wet material (REV. 01-03)

Wet material is the toughest material for any grinder to handle. If possible, try to mix the wet materials with drier materials before grinding. When grinding wet material, deposit small quantities on a more frequent basis rather than filling the tub with wet material.

### 3.23 Preparing the 3010 DURATECH TUB GRINDER for transport (REV. 01-03)

To prepare the 3010 DURATECH TUB GRINDER for transport over public roads, perform the following steps:

1. Be sure all loose parts such as screens, hammer rods, or extra hammers are properly stowed.
2. If the machine has folding flares, rotate the tub so the folding flares line up with the side of the machine.
3. If equipped with a magnetic roller, latch the discharge pan into the transport position.
4. Fold the discharge conveyor, and then raise the discharge conveyor into the transport position which is shown in figure 3.2 on the facing page. When folding the conveyor, do not exceed an engine speed of 1000 RPM. Excessive engine RPM will cause the conveyor to fold too fast and may cause damage. Be certain that no power lines, branches, roof trusses, etc. will obstruct the folding operation of the conveyor.



**CAUTION:** DO NOT MOVE TUB GRINDER without first securing the conveyor in transport position as shown in figure 3.2 on the facing page

5. If your machine is equipped with a tub cover, then lower tub cover.
6. Shut down the engine using the normal shutdown procedure.
7. Verify that the semi-tractor is properly coupled to the grinder hitch, and that the trailer wiring harness and air brake lines are properly connected to the semi-tractor.
8. Remove all loose materials such as leaves, grass, and branches from the machine.





9. Raise the trailer landing gear and lock the handle in its storage position.
10. Check the lights and the brakes for proper function.
11. Check local ordinances regarding restrictions for machine travel on local roads.

Read Section 1.12 “Towing” in the “Safety” section in this manual.

**figure 3.2**  
conveyor in the transport  
position





### **3.24 Preparing the 3010 DURATECH TUB GRINDER for operation after transport** (REV.01-03)

To prepare the 3010 DuraTech Tub Grinder for operation after transport, perform the following steps:

1. Check the location.
  - Are there power lines, branches, roof trusses, etc. that will obstruct the unfolding operation of the conveyor and the loading operation of the tub?
  - Position grinder to minimize the risk of thrown objects. For more information see section 1.6 on page 14.
2. Turn the battery disconnect switch to “ON”.
3. Perform pre-operation inspection of the tub grinder.
4. Start the engine.
5. Lower the conveyor fully.
6. Unfold the top section of the discharge conveyor until it is fully extended. When unfolding the conveyor, do not exceed an engine speed of 1000 RPM. Excessive engine RPM will cause the conveyor to fold too fast and may cause damage.
7. If equipped with a magnetic roller, unlatch the discharge pan and set it to a “working position”.
8. Raise the conveyor to operating height.
9. Set tub cover to desired position.

### **3.25 Preparing the 3010 DURATECH TUB GRINDER for storage** (REV.01-03)

To prepare the 3010 DURATECH TUB GRINDER for storage, perform the following steps:

1. The grinder has 4 pressure rollers with tapered roller bearings. These bearings should be regreased annually.
2. Change the hydraulic oil and filter every 500 hours of operation.
3. To prevent rust and make inspection easier, thoroughly clean the machine.
4. Check for loose or worn chains, belts, sprockets and pulleys.
5. Check the condition of bearings.
6. Make sure that the batteries are fully charged before storing the unit, and turn the battery disconnect switch to “OFF”.
7. Change the engine oil and filter.



### 3.26 Removing the 3010 DURATECH TUB GRINDER from storage

(REV. 01-03)

To remove the 3010 DURATECH TUB GRINDER from storage, perform the following steps:

1. Perform a thorough pre-operation inspection as specified in Section 3.1 (page 27) of this manual.

### 3.27 Installing a screen

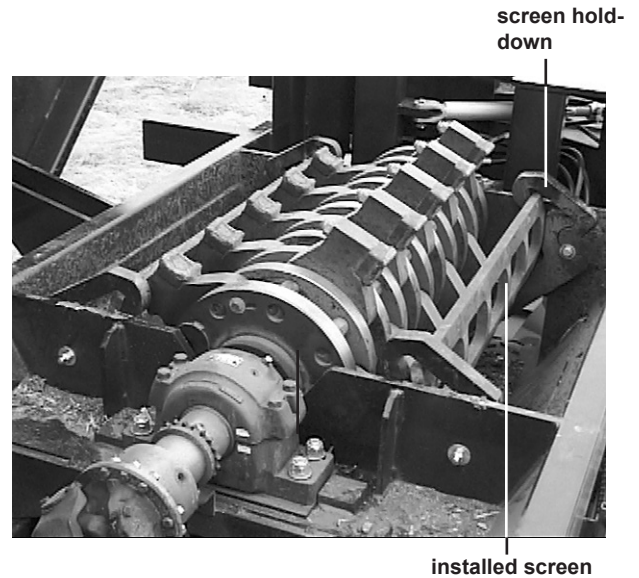
(REV. 01-03)



**CAUTION:** Follow normal shutdown procedure after tilting the tub and prior to performing any service work in the rotor area.

To install a screen, perform the following steps:

1. Raise the tub completely, and install the hydraulic cylinder lock.
2. Unlatch the screen hold-downs.
3. Screens may be lifted from or placed in the machine with a hoist or lifting device.
4. Securely attach the screen to the lifting device with a sturdy chain or nylon sling. Stuck screens can require a force many times their weight to lift them free of the grinder.
5. Use only pry bars to guide the screens in and out of the machine. The screens are very heavy and could easily cause injury if the screen moves suddenly or is inadvertently dropped.
6. Clear all material from the screen track before installing a new screen.
7. Install the new screen using the lifting device and pry bars as explained above.
8. Make certain that the screen fits completely in place, and latch the screen hold-downs.
9. Make sure all personnel and equipment are clear of the tub platform.
10. Remove the hydraulic cylinder lock, and lower the tub.





### 3.28 Adjusting the conveyor belt tension

(REV. 01-03)



**IMPORTANT:** Do not overtighten conveyor belts. Use only enough tension to eliminate belt slippage.

Both rollers on the belly conveyor and the discharge conveyor are adjustable to allow for belt stretch and tracking. If the conveyor belt slows down or stops during operation, slippage may be the cause. To eliminate slippage, tighten the adjusting bolts on the conveyor equally. This will increase the conveyor belt's tension and help to keep the belt centered on the rollers.

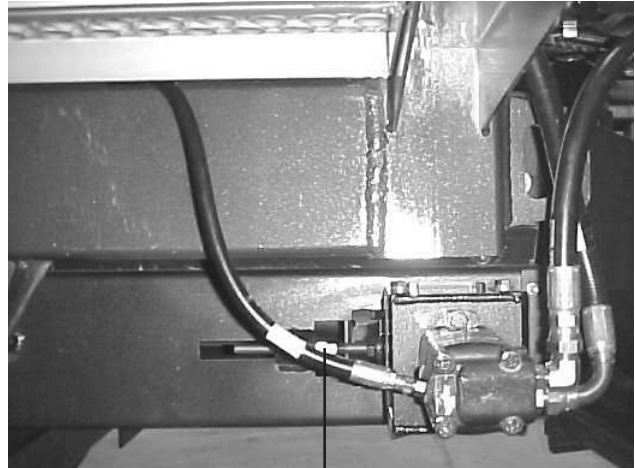
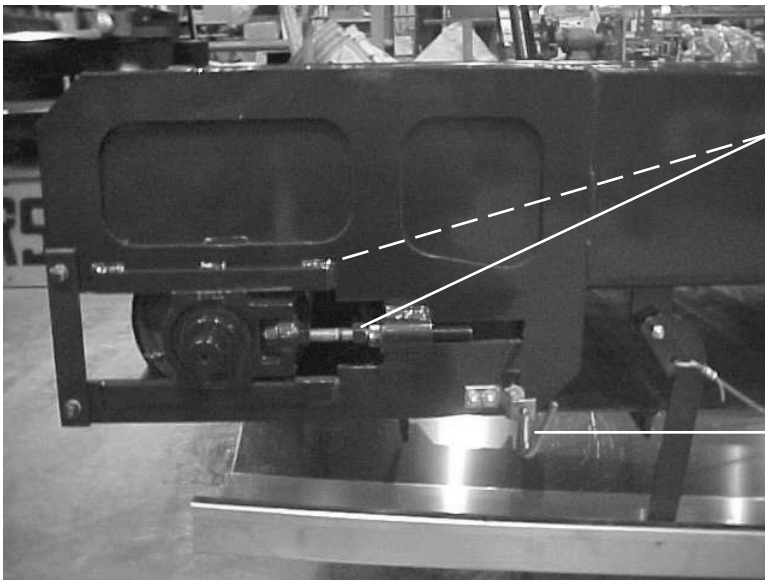


figure 3.3  
belly conveyor belt  
adjusting bolt



adjustment bolts

discharge pan latch

discharge pan

see section  
3.23 & 3.24

figure 3.4  
discharge conveyor  
belt adjusting bolts



### 3.29 Adjusting the conveyor belt tracking

(REV. 05-04)

#### A. When a new belt is installed, use only genuine DuraTech Industries parts.

1. Begin by adjusting the drive roller so that the mounting bearings are the same distance from the end of the conveyor frame. This ensures that the roller centerline is square with conveyor frame. Adjust the idler roller bolts so that they are equal on both sides of the conveyor.

#### B. If the belt is running to the right side, perform the following steps:

1. Adjust the idler roller adjustment bolt on the right side of the conveyor (figure 3.4 & 3.5). Increase tension by approximately 1/2 turn of the adjusting nut.
2. Make certain that all personnel are clear of machine and the start engine. Engage the hydraulic conveyor drive switch.
3. Observe conveyor belt tracking from a safe location.
4. If further adjustment is required, disengage hydraulic conveyor drive switch and shut down the machine using the normal shutdown procedure.
5. Some adjustment of the drive roller may be required if no improvement is noted by adjusting the idler roller tension.
6. Repeat steps 1-5 until proper tracking is achieved.

#### C. If the belt is running to the left side, perform the following steps:

1. Adjust the idler roller tension bolt on the left side of the conveyor. Increase the tension by approximately 1/2 turn of the adjusting nut.
2. Make certain that all personnel are clear of machine and start engine. Engage the hydraulic conveyor drive switch.
3. Observe the tracking of the conveyor belt from a safe location.
4. If further adjustment is required, disengage hydraulic conveyor drive switch and shutdown using the normal shutdown procedure.
5. Some adjustment of the drive roller may be required if no improvement is noted by adjusting the idler roller tension.
6. Repeat steps 1-5 until proper tracking is achieved.

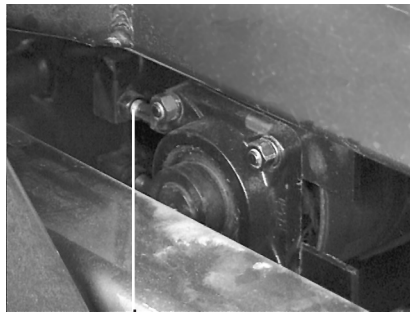
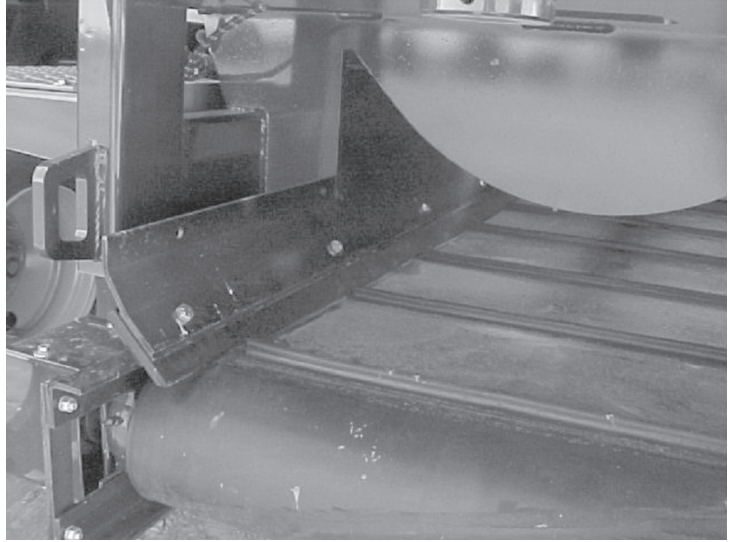


figure 3.5  
tracking adjustment  
bolt  
(belly conveyor)



### 3.30 Adjustable belly belt seals (REV. 05-04)

1. Always make sure the belt seals (pn # 1700166) and endless belt are in contact with each another.
2. When adjusting the belt seal as it wears down, loosen the bolts and push belt seal down so that it comes in contact with the endless belt again.
3. Note that the adjustment bolts should be pointed outward.

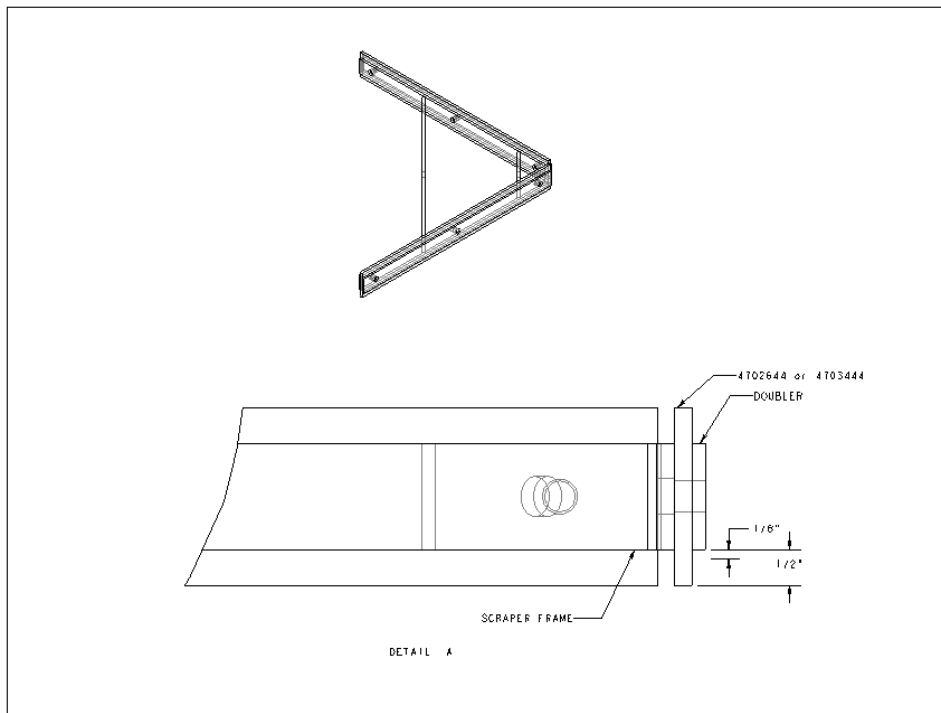


### 3.31 Belt scrapers on belly and discharge conveyors (REV. 05-04)

Belt scrapers have a poly blade (pn# 4702644 for the belly or pn# 4703444 for the discharge) that wears down and needs to be flipped around or replaced. When the poly blades wear to within 1/8" of the scraper frame and doubler, either flip the poly blade around or replace with a new one.



**Note:** the belt scrapers are located inside the belt.



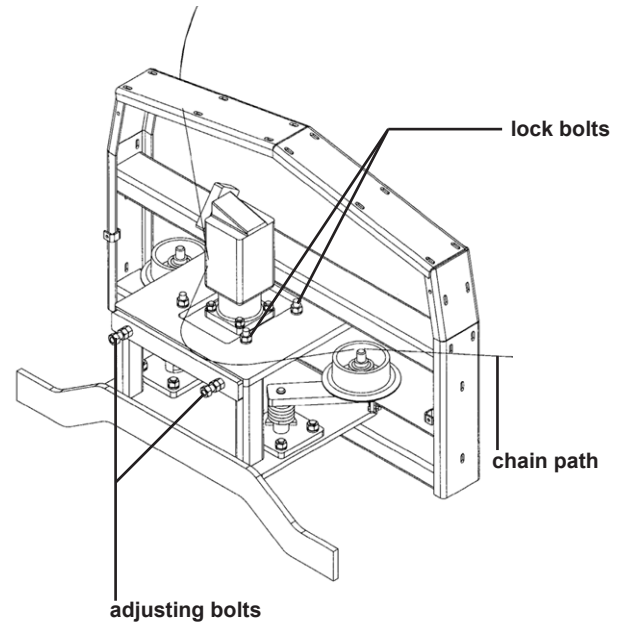




### 3.32 Adjusting tub chain tension (REV. 01-03)

To adjust the tub chain tension, perform the following steps:

1. Loosen (4) bolts holding motor mounting plate.
2. Turn (2) adjusting bolts to set chain tension.
3. Tighten the (4) bolts holding motor mounting plate.



### 3.33 Engaging wet clutch (REV. 04-03)



**IMPORTANT:** Read and have a thorough understanding of the wet clutch operators manual.



**IMPORTANT:** Never engage the clutch when platform is raised.

To engage the wet clutch, perform the following steps:

1. Before starting engine, the rotor box should be cleared of all material.
2. Start the engine. Engine must be at 800-1100 rpm; the controller will not engage the wet clutch when engine speed is above 1100 rpm. The “POWER” LED and the “ENGINE RPM” LED will be illuminated.
3. Push the Clutch Start Button in for about 3 seconds. (The blue beacon light should be lit during this time). When the “CLUTCH ENGAGE” symbol illuminates, the Start Button can be released.

### 3.34 Disengaging the wet clutch (REV. 04-03)

To disengage the wet clutch:

1. Empty the tub.
2. Reduce engine speed to below 1200 rpm.
3. Push the Clutch Start Button for 1 second. The wet clutch will disengage, and the “CLUTCH ENGAGED” symbol will not be illuminated.





### 3.35 Electro-hydraulic valve coil test (REV. 01-03)

See the figure 3.7 for the location of the electro-hydraulic valve coil.

This test requires an accurate ohm meter. Disconnect the wiring harness leads at the electro-hydraulic valve coil. Check resistance of valve coil leads at the terminals. The resistance should be between 38 to 44 ohms. If the values are not within this range, replace the electro-hydraulic valve coil.

#### MANUAL OVERRIDE

NOTE: If there is an electrical failure with the machine, it may still be able to grind. Switch the electronic governor off. Remove the rubber end cap and loosen the jam nut on the electro-hydraulic valve. Start the machine and engage the tub drive.

figure 3.6  
electronic governor system

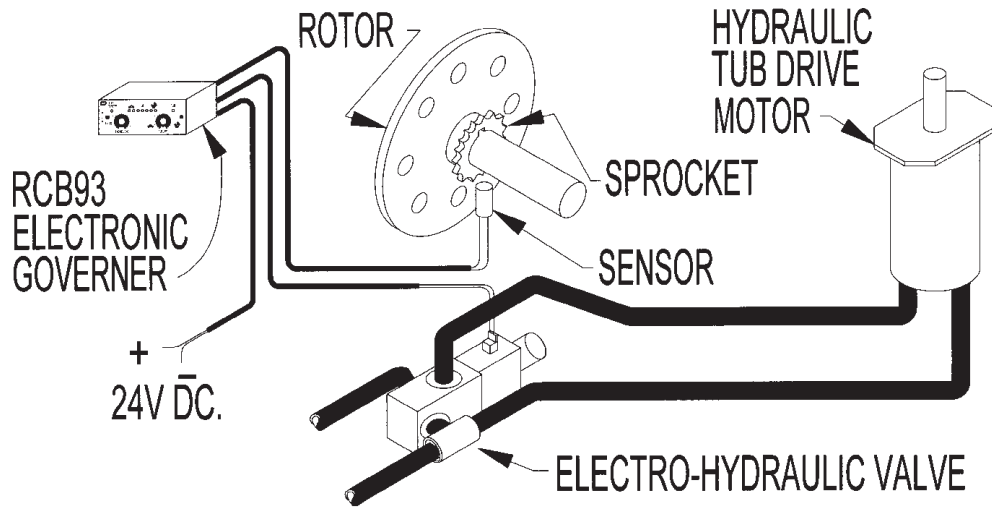
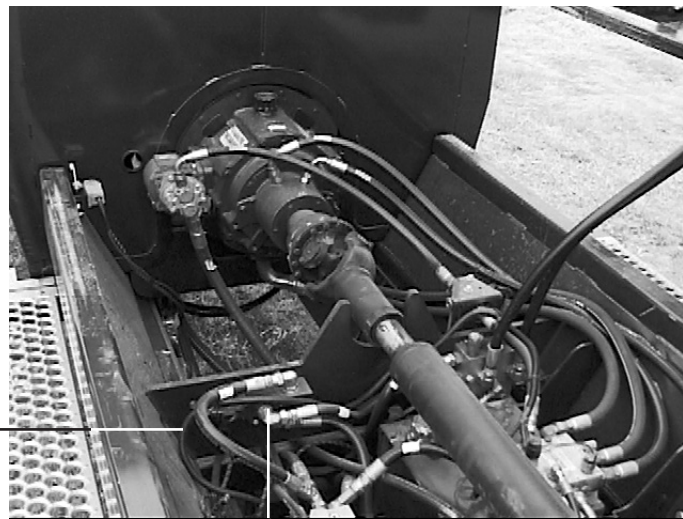


figure 3.7  
location of the  
electro-hydraulic  
valve

location of adjusting nut and jam nut  
found under rubber cap end



electro-hydraulic valve



**IMPORTANT! - DO NOT ENGAGE THE WET CLUTCH AT THIS TIME!**

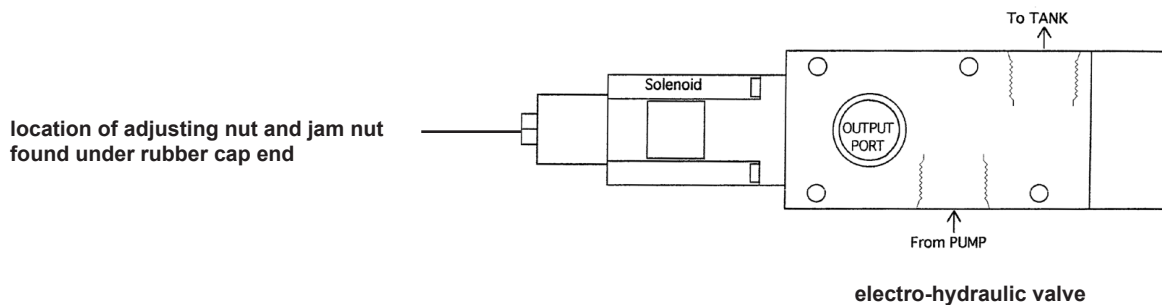
Turn the adjusting stud clockwise until the tub rotates at the desired speed. Lock the jam nut on the adjusting stud and replace the rubber end cap on the electro-hydraulic valve. When the electro-hydraulic valve is adjusted in this manner, it will function only as a manual flow control. The grinder will now operate as it would if the electronic governor were switched to the tub (manual) mode. The tub speed will be constant and it will not change to match varying load conditions.

Contact your dealer for repairs or replacement parts. When the problems are corrected, calibrate the electro-hydraulic valve as described in the next section.

### 3.36 Electro-hydraulic valve calibration (for SN up to GJ 3090) (REV. 04-11)



**IMPORTANT:** Stay clear of all moving parts while calibrating the electro-hydraulic valve. **The tub will be rotating during this adjustment.**

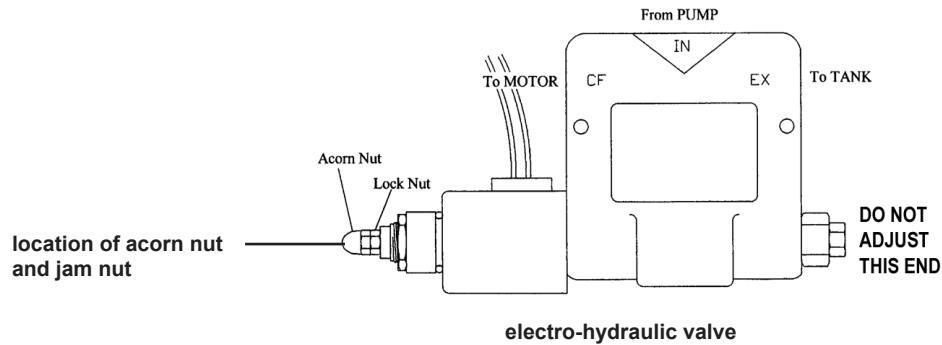


To calibrate the electro-hydraulic valve coil after following the three steps above, perform the following steps:

1. Remove the rubber end cap from the end of the electro-hydraulic valve. This will reveal a jam nut and an adjusting stud with a screwdriver slot.
2. Disconnect the wiring harness from the electro-hydraulic valve coil, and loosen the jam nut.
3. Start the engine, and engage the tub drive in the forward direction. Throttle the engine up to a fast idle. **Do not engage the wet clutch!**
4. If the tub is not rotating, turn the adjusting screw clockwise until it bottoms out. Turn the adjusting screw counterclockwise until the tub stops. The electro-hydraulic valve is now calibrated.
5. Lock the adjusting screw with the jam nut and replace the rubber cap. Shut down the machine using the normal shutdown procedure in this manual. Reconnect the wiring harness to the electro-hydraulic valve coil.



### 3.36a Electro-hydraulic valve calibration (for SN GJ 3090 and up)



To calibrate the electro-hydraulic valve coil after following the three steps above, perform the following steps:

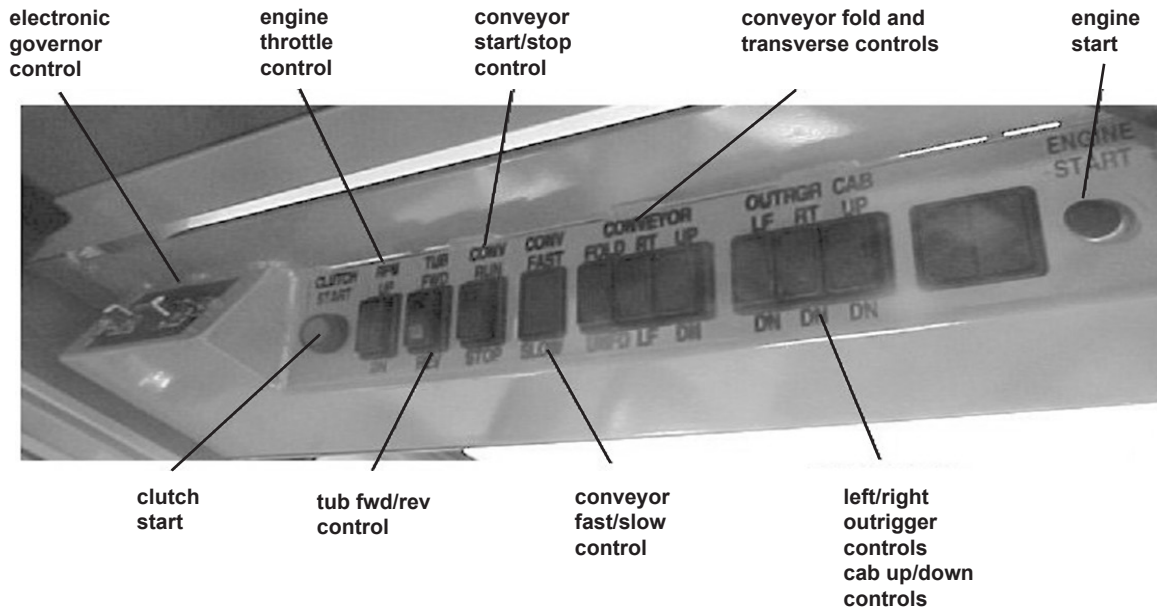
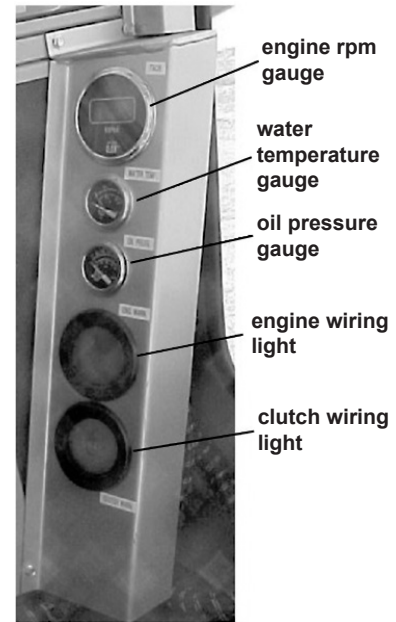
1. Shut down the machine using the normal shutdown procedure in this manual
2. Disconnect the wiring harness from the electro-hydraulic valve coil.
3. Remove the acorn nut from the end of the electro-hydraulic valve. This will reveal a jam nut and an adjusting stud with a screwdriver slot.
4. Loosen the jam nut.
5. Turn the adjusting screw counterclockwise until it stops.
6. Lock the adjusting screw with the jam nut and replace the acorn nut. Reconnect the wiring harness to the electro-hydraulic valve coil.



### 3.37 3010 Grapple Loader Option (REV. 04-05)

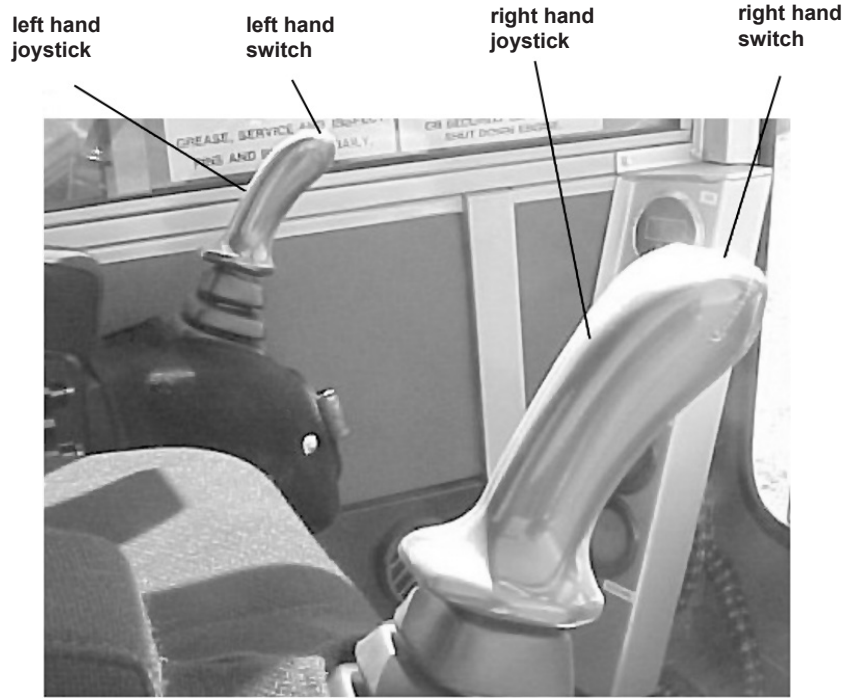
An optional grapple loader is available for the 3010 Industrial Tub Grinder. This loader can be used to place most materials into the grinder's tub. From the loader's cab, the operator is able to see what is occurring in the tub.

Stabilizer legs are included with the optional loader, and their controls are located in the operator's cab with the controls for operating the loader. The stabilizer legs stabilize the loader during operation.

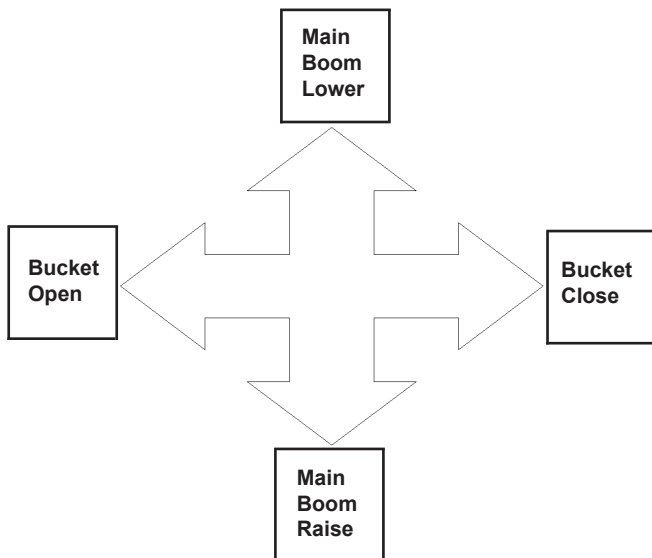




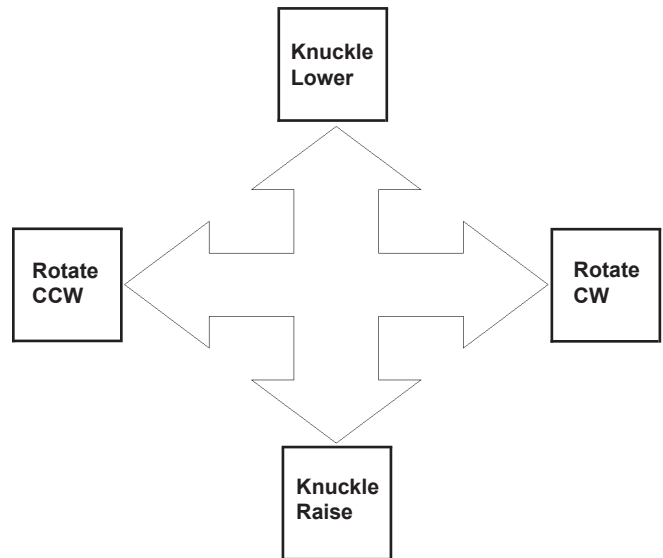
## Joystick Controls for 3010 Grapple Loader



Left Hand Joystick Controls



Right Hand Joystick Controls



### Switches on the Joysticks

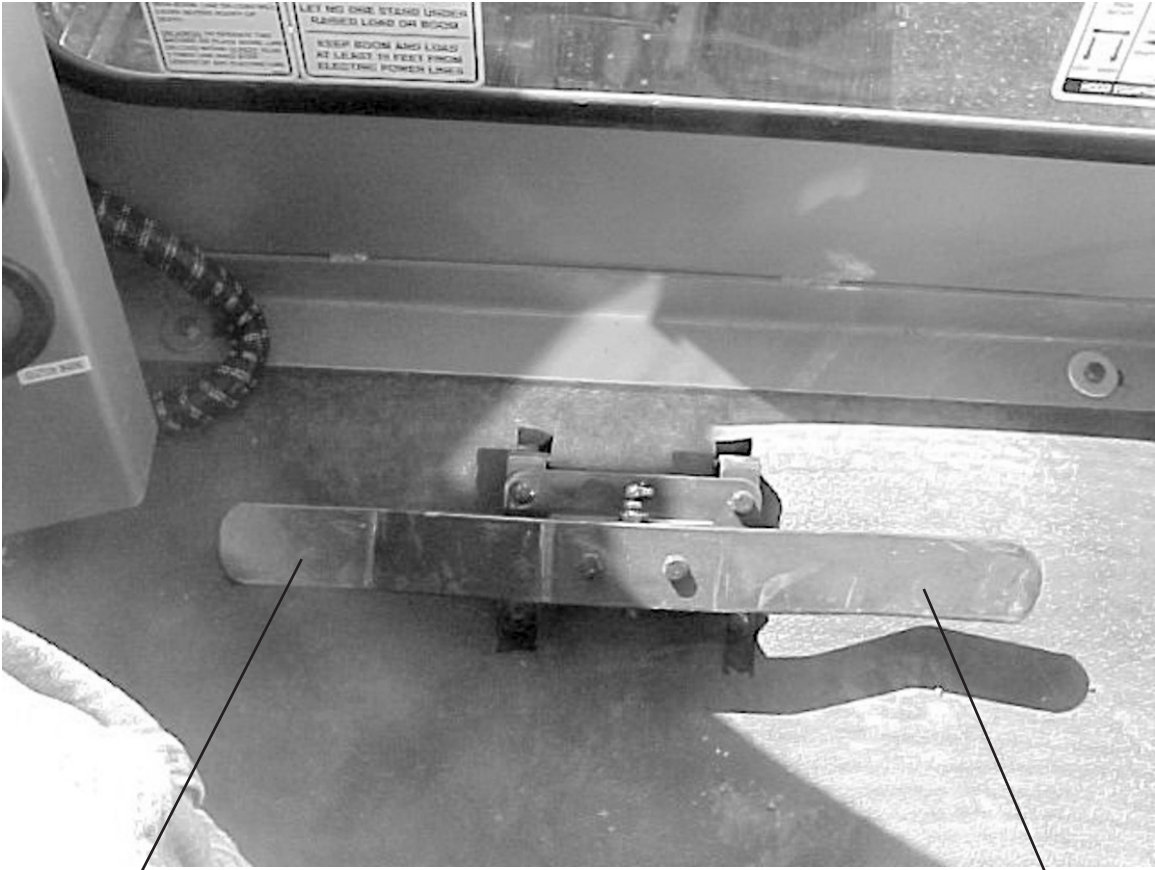
With the Tub Cover: Left switch controls the IN/OUT. Right switch controls the UP/DOWN.

With no Tub Cover, the switches are used for the discharge conveyor: Left switch controls the UP/DOWN for the discharge conveyor.

Right switch controls the SWING LEFT/SWING RIGHT.



### Foot Controls



Rotates boom left

Rotates boom right





### 3.38 3010 Track Option (REV. 06-14)



**3010 Track Machine**

#### **Running the 3010 track using manual controls**



**Manual Lever Controls**

(seen from above)

The manual controls are located on the front of the 3010 Track. To move the 3010 Track using these controls, simply push the levers forward to go forward, pull the levers backward to go backwards, or for turning, operate one lever opposite the other.

#### **Running the 3010 track using the remote control**

A remote control may be used instead of the manual levers. The remote control also has two joysticks on it to move the 3010 Track.





### Remote Control For The 3010 Track

#### STARTING THE ENGINE WITH THE REMOTE CONTROL

1. Start the engine with radio/local switched to local.
2. Turn radio on.
3. Press and hold the start button next to the radio/local switch and switch radio/local switch to radio.
4. Depress the E-Stop button.
5. Twist E-Stop to release button and the green light on the remote will light up. (If green light does not come on retry above procedure)
6. Release the start button.



Remember the track speed **must** be set on low for a remote start up.

#### ENGINE SPEEDS

Tracks should be started in low and shifted to high.

#### CONTROL PANEL FOR THE 3010 TRACK

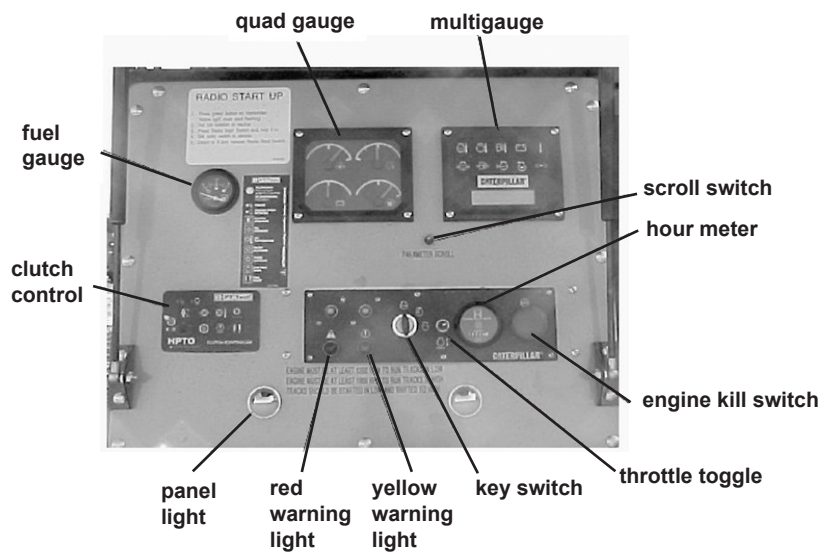
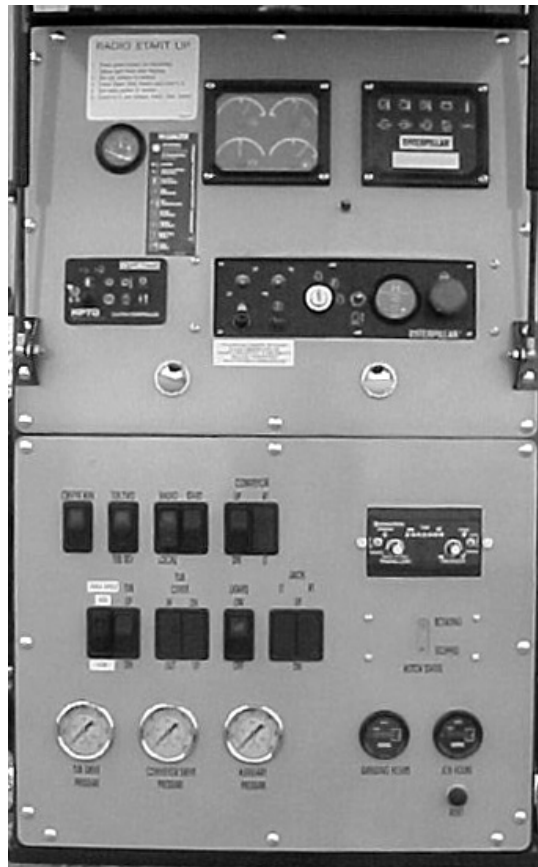
The control panel is located on the left hand side of the engine.

Controls on the control panel include; engine start, emergency kill switch, throttle, tub controls, conveyor on/off, conveyor positioning, rotor engage, rotor disengage button, tub governor, tub tilt, and the job hours reset button.

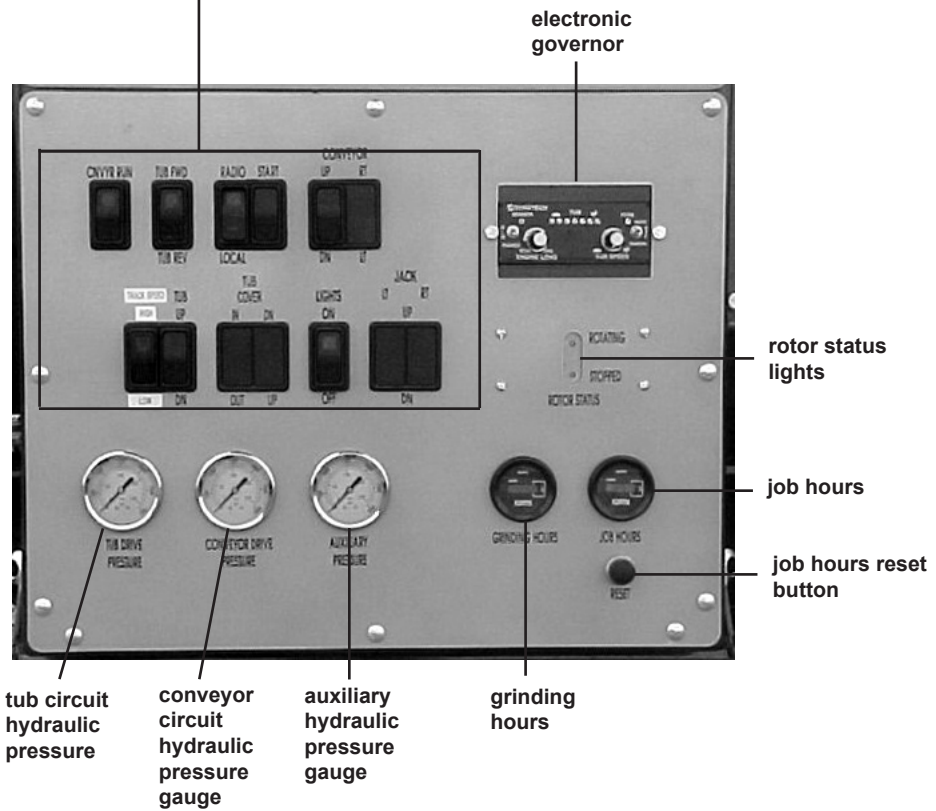
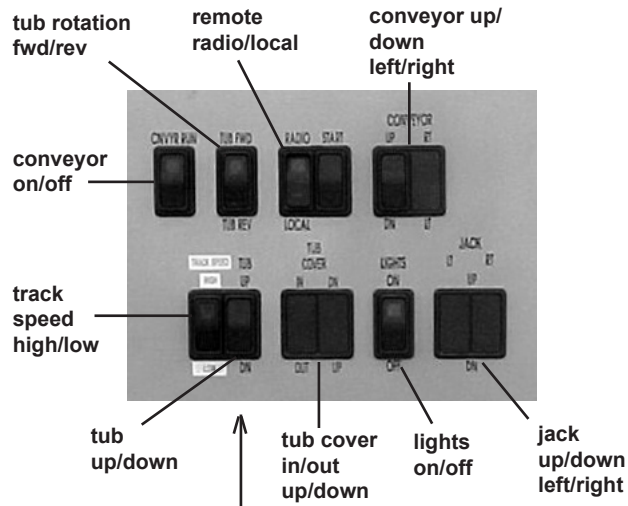


Gauges on the control panel include; tub circuit hydraulic pressure, conveyor hydraulic pressure, auxiliary hydraulic pressure, fuel level, grinding hours gauge, job hours gauge and a quad gauge with engine oil pressure, battery, engine temperature and fuel level, and a multi gauge.

### Control Panel (CAT Tier II)



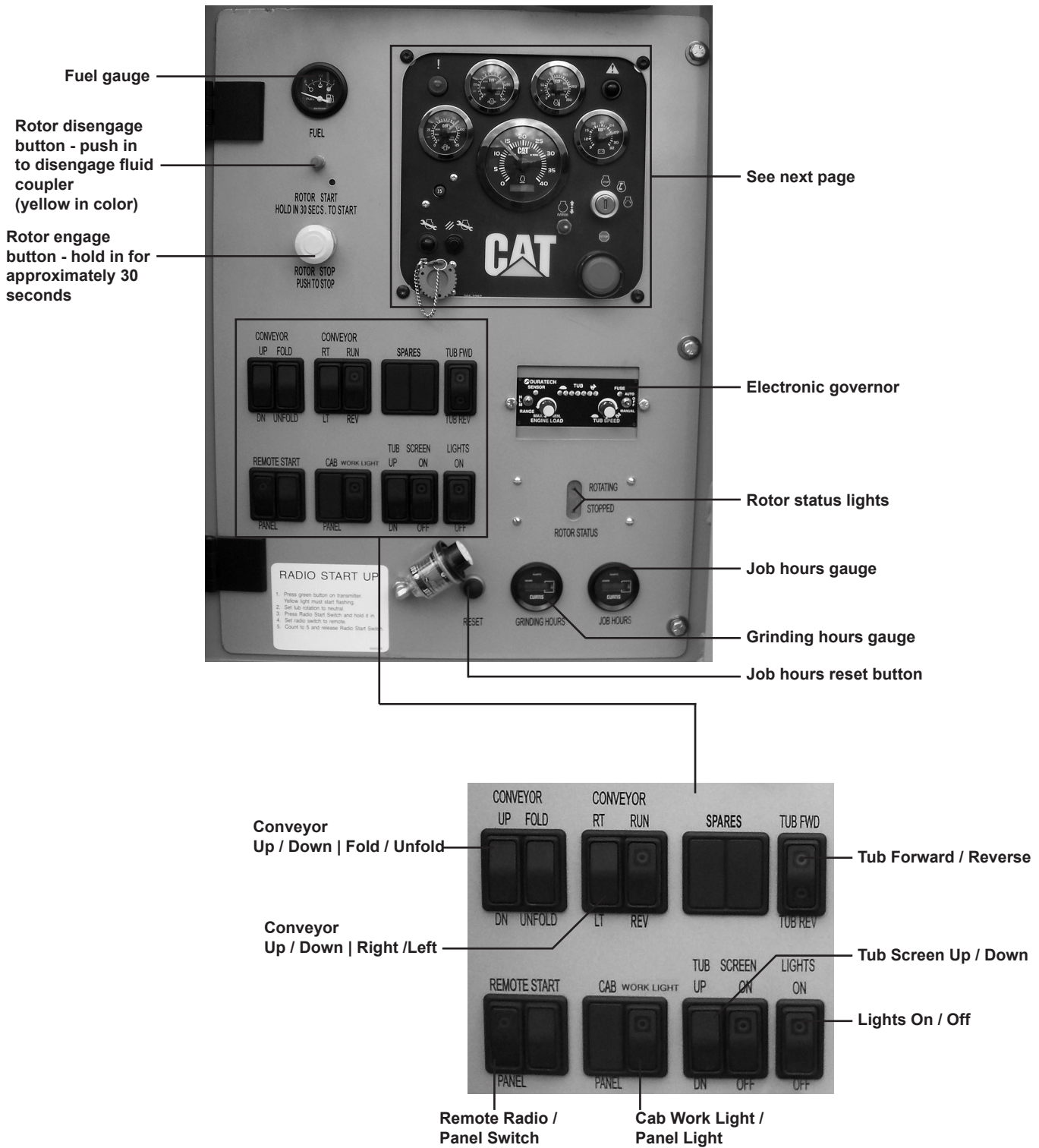
### Top Control Panel



**Bottom Control Panel**

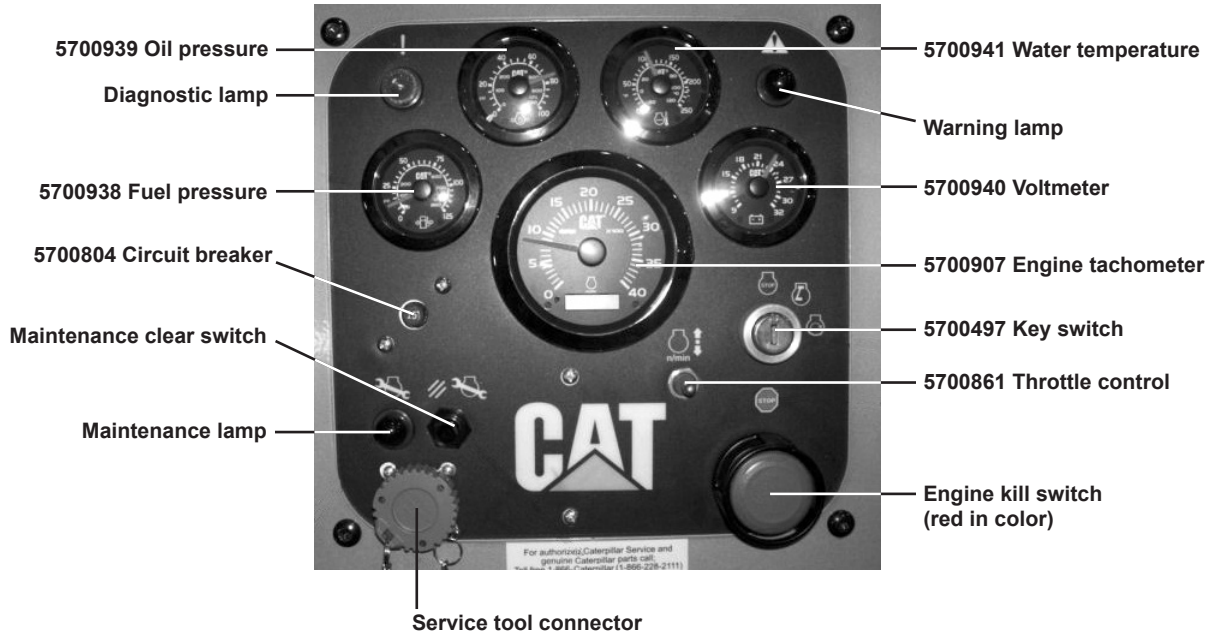


## Control panel (S.N. 3130 And Up)





## CAT Control Panel for Tier III Engines







## Conveyor Locking Pins



conveyor locking pins

Always use the pins to lock up the conveyor during hauling.



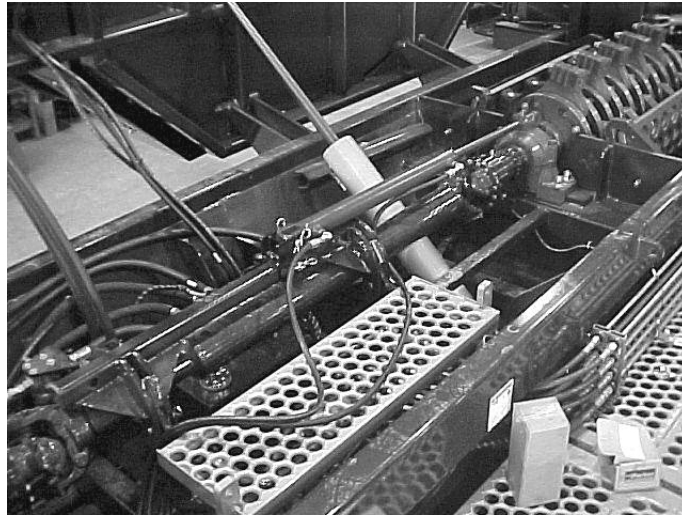


### 3.39 3010 Hydraulic Hammer Rod Puller (Optional) (REV. 04-11)

#### A. Operation

##### A. Rod Removal

- i. Loosen bolts on rotor end-plate and rotate it.
- ii. Turn in eye-bolt, 4800600, into the end of rod to be pulled.
- iii. Pin up the cylinder as in picture 1 and pin rod end to the eye-bolt.
- iv. Retract the cylinder. If the rod does not move at first, use a 5 lb. hammer to tap on the rod and rotor plates to help loosen the rod.
- v. Once the cylinder is fully retracted, unpin the cylinder mount from the base and extend the cylinder until the mount can be pinned in the 'rear' position.
- vi. Retract cylinder and remove the rod.



Picture 1

##### a. Rod Install

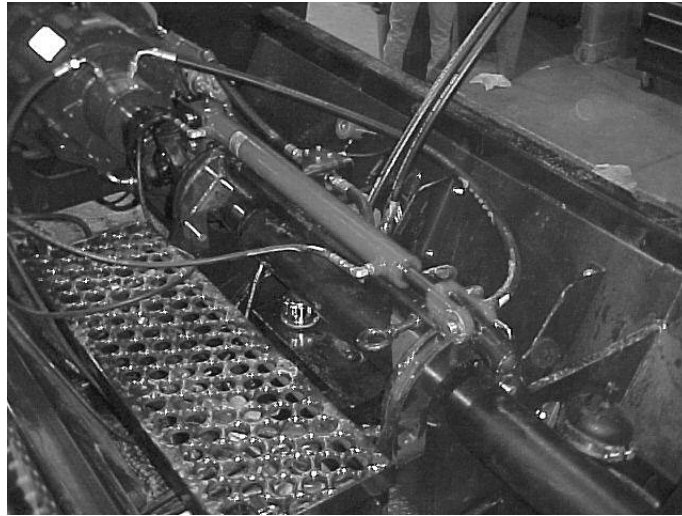
- i. With the cylinder positioned as in picture 2 install the "cup" (4703973) on the end of the cylinder.
- ii. With the rotor plates aligned and the rod inserted through at least two plates, position the cup over the end of the rod and extend the cylinder.



**WARNING:** Keep hands and feet away from the rod and cylinder while operating the cylinder. Stop cylinder function if a rotor plate must be aligned to accept rod!



- ix.** Adjust the cylinder mount to the 'front' position and continue pushing the rod the rest of the way. Rod will still need to be tapped in flush with the first plate.



Picture 2

## **B. Storage**

### **A. Cylinder**

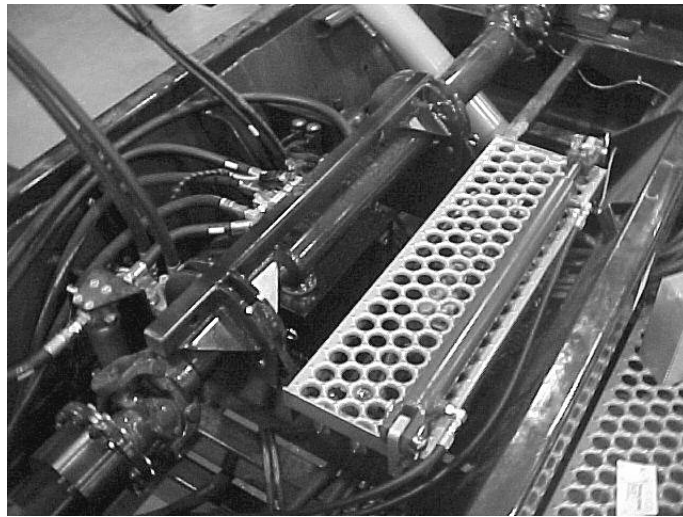
- i.** Retract the cylinder and remove it from the rod puller frame.
- ii.** Pin the cylinder to the service step as shown in picture 3.

### **B. Frame**

- i.** Remove the 4 pins from the rod puller frame and lift the puller frame assembly out of the main frame.
- ii.** The puller assembly can be stored on the bracket underneath the walkway.

### **C. Harness/Hoses**

- i.** Tie down remote harness and hoses out of the way of the driveshaft and tub using wire ties or bungee cords.



Picture 3



## Section 4: Engine Maintenance

Engine oil level, engine coolant level, air filters, and fan belt tension should be checked daily. All debris, and combustible or ignitable material should be cleared from the engine compartment daily or more often as conditions warrant. When cleaning the engine compartment, pay particular attention to the top of the engine. Follow the engine manufacturer's recommendations for the replacement of parts and fluids, and follow the manufacturer's recommended maintenance schedule. Engine specifications should be found in the Operation and Maintenance manual for the engine.

## Section 5: General Maintenance



**WARNING:** Before servicing machine, read the Service and Maintenance section of the Safety Instructions.



**IMPORTANT:** If for any reason arc welding is to be done, always ground rotor to frame of machine to prevent arcing in bearings.

### 5.1 Welding Procedure (REV. 01-03)

Welding on a machine that is equipped with an Electronic Engine.

Proper welding procedures are necessary in order to avoid damage to the computerized equipment. Computerized equipment includes but is not limited to the following; the Engine Control Module (ECM), electronic governor, HPTO Control Module, Omnex Radio Receiver (if equipped), and ABS Controller (if equipped).

If at all possible, the component that is to be welded should be removed from the machine for welding. If removal of the component is not possible, the following procedure must be followed when welding on a machine that is equipped with electronic engine. This procedure is considered the safest and should provide minimum risk of electronic component damage.



**NOTE:** Do not ground the welder to electrical components such as the ECM or sensors. Improper grounding can also damage the drive train bearings or hydraulic components. Clamp the ground cable from the welder to the component that will be welded. Place the clamp as close as possible to the weld. This will help reduce the possibility of damage.



1. Stop the engine. Turn the battery disconnect switch to the OFF position.
2. Disconnect the negative battery cable from the battery.
3. Disconnect the connectors from the computerized equipment listed on the previous page. Move each harness to a position that will not allow the harness to accidentally move back and make contact with any of the connector pins.
4. Connect the welding ground cable directly to the part that will be welded. Place the ground cable as close as possible to the weld in order to reduce the possibility of welding current damage to the bearings, hydraulic components, electrical components, and ground straps.



**NOTE:** If the electrical/electronic components are used as a ground for the welder, or electrical/electronic components are located between the welder ground and the weld, current flow from the welder could damage the components.

5. Protect the wiring harness from welding debris and spatter.
6. Use standard techniques to weld the materials.



electronic governor



## 5.2 Batteries (REV. 01-03)

Check the condition of the batteries to insure that the electrolyte level is correct. Make sure that the terminals and cables are not corroded, and that the battery is held in place properly. Also make sure there is no arcing or grounding by the terminals.

The system uses two 12 volt batteries in series to produce a 24 volt system for the engine.



**CAUTION:** Hydrogen gas given off by a battery is explosive. Keep sparks and flames away from the battery. Before connecting or disconnecting a battery charger, turn the charger off. Make last connection and first disconnection at a point away from the battery. Always connect the NEGATIVE(-) cable last and disconnect the NEGATIVE(-) cable first.

## 5.3 Lubrication (REV. 01-03)



**CAUTION:** Always shut off machine before adjusting or lubricating. When grinder is operated during cold weather, all lubrication should be performed after bearings are at operating temperatures.

Since a full bearing with a slight leakage is the best protection against entrance of foreign material, bearings operating in the presence of dust and water should contain as much grease as speed will permit. At higher speed ranges, too much grease will cause the bearings to overheat.

Abnormal bearing temperature during high speed operation may indicate faulty lubrication. The normal temperature may range from cool to warm to the touch. If a bearing is too hot to touch for more than a few seconds and the bearing is leaking grease excessively, there is too much grease in the bearing. High bearing temperatures with no grease showing at the seals, particularly if the bearing seems noisy, usually indicates too little grease. Normal temperature and slight showing of grease at the seals indicate proper lubrication.

The Lubrication Chart is a general guide for “relubrication”. Certain conditions may require a change of lubrication periods as dictated by experience.

A heavy-duty, general-purpose, lithium-based grease is recommended for lubricating the 3010 DuraTech Tub Grinder.



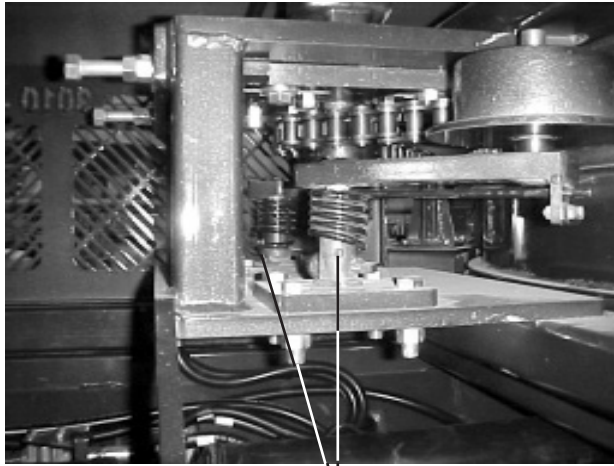


# LUBRICATION CHART

STANDARD EQUIPMENT				
REF. NO.	LOCATION	NO. OF ZERKS	FREQUENCY	REFERENCE SECTION #
1	Rotor brg, check oil level (For S.N. up to HJ3114)		Daily	5.5
1a	Rotor bearings (For S.N. IJ3115 and up)	2	Daily	5.5a
2	Wet clutch, check oil level		Daily	5.7
3	Hydraulic system, check oil level		Daily	5.6
4	Tub chain idler pivot	2	Daily	
5	Wheel bearings, check oil level		Daily	5.8
6	Roller chains		1. Daily in dusty conditions or as needed 2. Use graphite lubricant	5.4
7	Drive line	5	40 Hours	
8	Tub rollers	0	Sealed	5.4
9	Discharge conveyor rollers	4	40 Hours	
10	Discharge conveyor pivot	2	40 Hours	
10a	Discharge conveyor fold pivot	2	40 Hours	
11	Discharge conveyor lift pivot	2	40 Hours	
12	Belly conveyor	4	40 Hours	
13	Tub pivot, 90 deg tub tilt	2	40 Hours	
14	Jack stands	5	40 Hours	
15	Axles	12	40 Hours	5.8
16	Radiator fan pulley	1	40 Hours	
17	Rotor brg, change oil		500 Hours	5.5
18	Wet clutch	2	2 Shots per zerk 500 Hours	5.7
19	Tub pressure roller, inspect and repack	2	1000 Hours	5.4
20	Radiator pivots	2	Annually	
21	Clutch, change oil		Annually	5.7
OPTIONAL EQUIPMENT				
22	Vertical tub cover frame	4	40 Hours	
23	Tub cover	2	40 Hours	

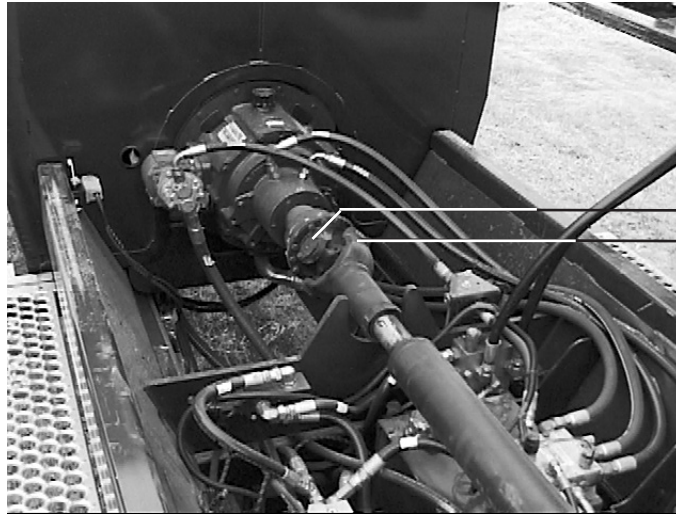


figure 5.1  
tub chain idler  
lubrication points



tub chain idler pivots (Ref # 4)

figure 5.2  
drive line lubrication  
points



lubrication zerk (Ref # 7)  
lubrication zerk (Ref # 7)

figure 5.3  
discharge conveyor  
lift, and discharge  
conveyor pivot  
lubrication points

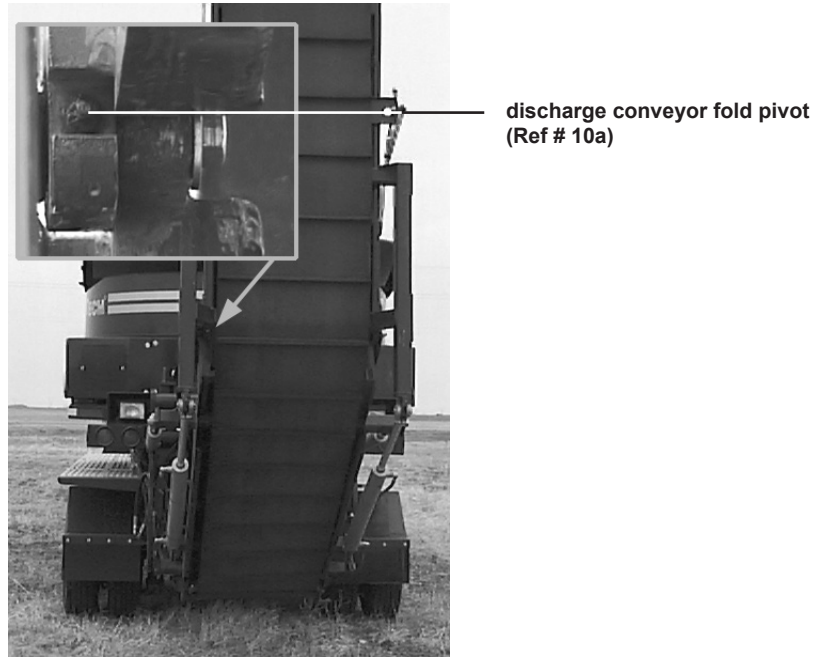


discharge conveyor pivot  
(Ref # 10)

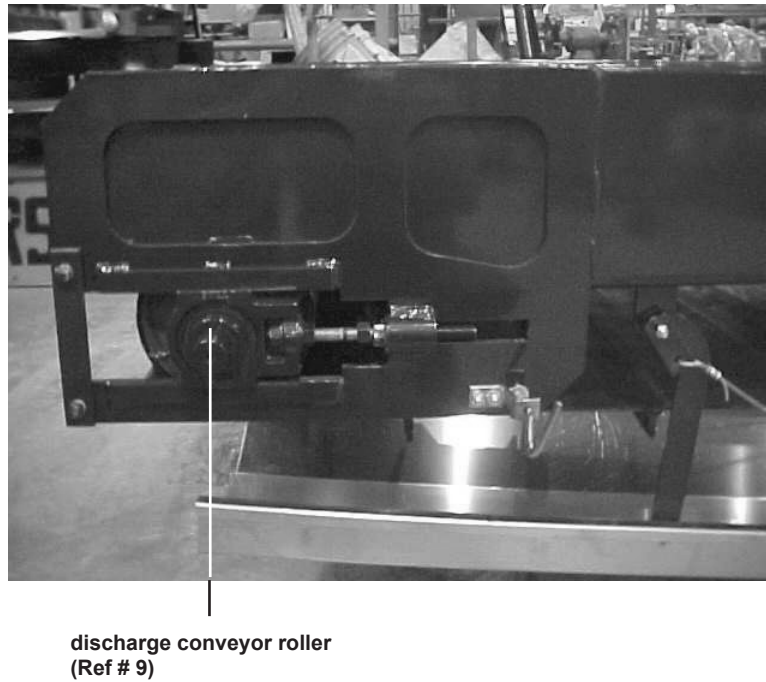
discharge conveyor lift pivot  
(Ref # 11)



**figure 5.4**  
conveyor fold pivot  
lubrication point



**figure 5.5**  
discharge conveyor roller  
lubrication point





**figure 5.6**  
belly conveyor roller &  
discharge conveyor  
roller lubrication points



belly conveyor roller  
(Ref # 12)

discharge conveyor roller  
(Ref # 9)

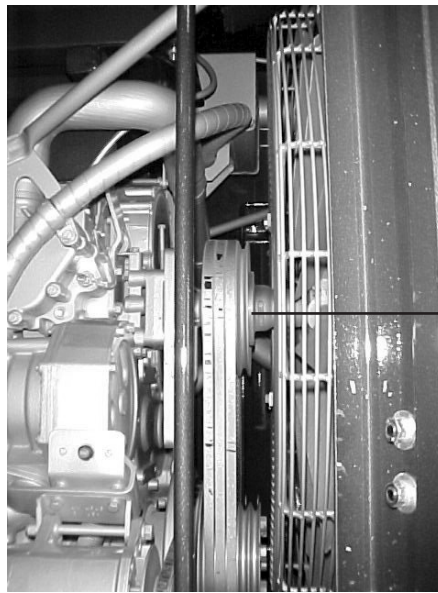
**figure 5.7**  
tub pivot lubrication  
points



tub pivots  
(Ref # 13)



figure 5.8  
radiator fan pulley  
lubrication point



radiator fan pulley  
(Ref # 16)

figure 5.9  
radiator pivot  
lubrication points

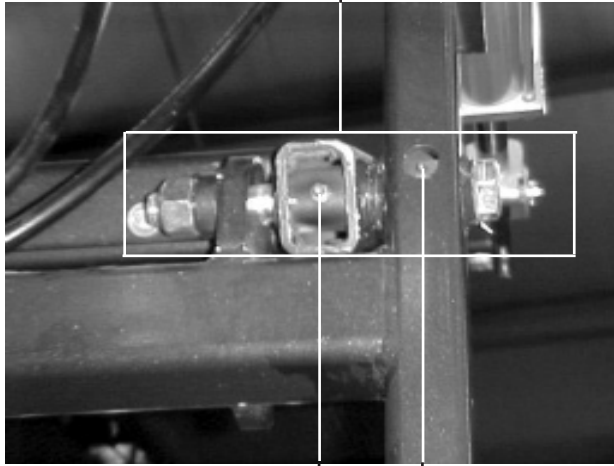
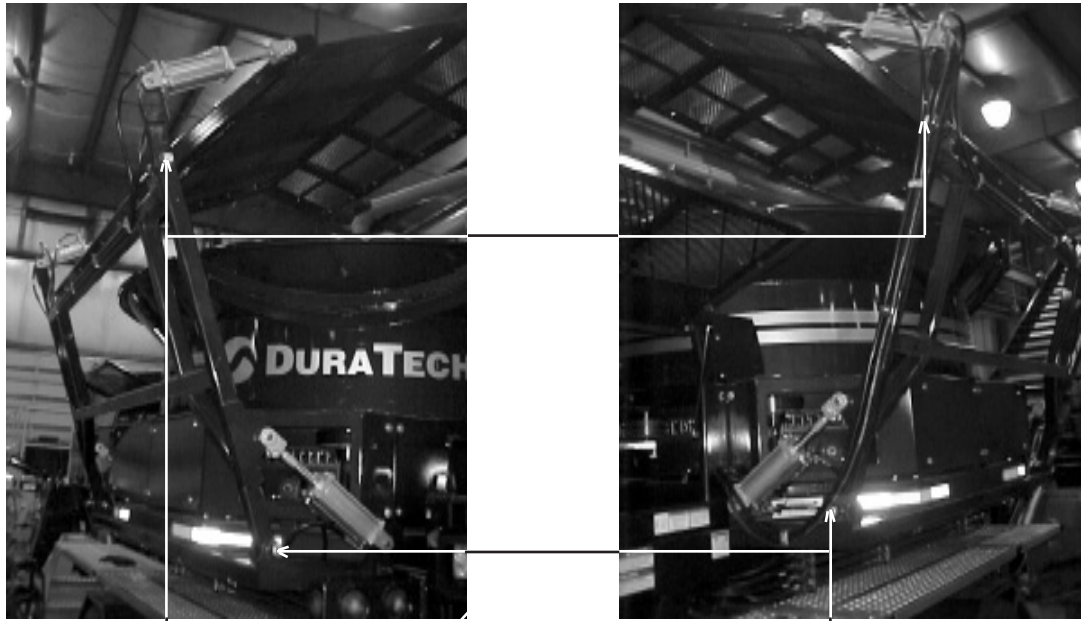


radiator pivots  
(Ref # 20)

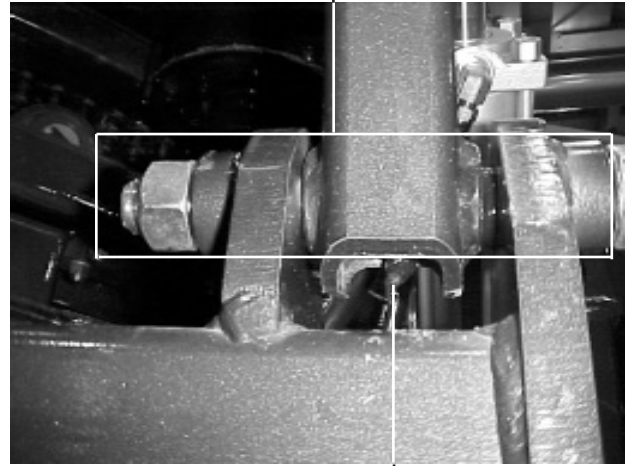




figure 5.10  
optional tub cover  
lubrication points



tub cover  
(Ref # 23)



vertical tub cover frame  
(Ref # 22)

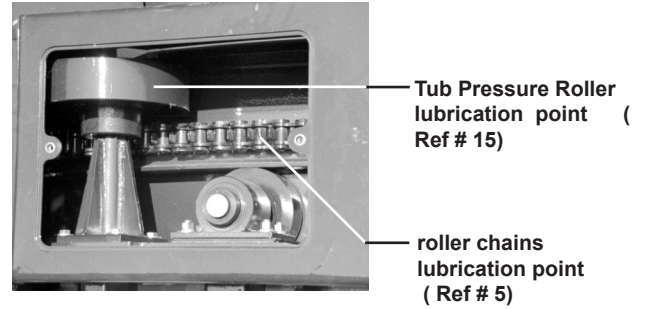




## 5.4 Pressure roller lubrication

(REV. 01-03)

The grinder has a pressure roller with tapered roller bearings. These bearings should be checked for lubrication every 1000 hours of operation or annually- whichever comes first. These bearings should be checked for proper adjustment daily.



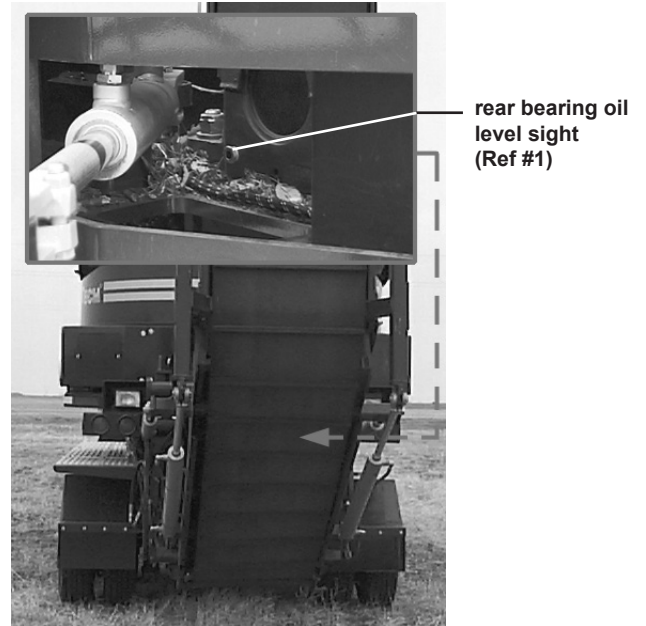
## 5.5 Rotor bearing lubrication (S.N. Up to HJ3114)

(REV. 06-14)

As a general rule, rotor bearing oil should be replaced every 500 hours of operation. However, if the oil becomes discolored or milky in appearance, the oil should be replaced immediately.

The static oil level should bring oil to the centerline of the bottom roller. The oil level in the sight glass should be centered in the sight glass.

When adding or replacing rotor bearing oil, use Mobil SHC-626 oil or other similar oil, but never use a detergent motor oil.



## 5.5a Rotor bearing lubrication - Dodge Imperial ISAF Bearing lubrication (SN IJ3115 & up)

(REV. 06-14)

Imperial spherical roller bearings are lubricated at the factory with Mobilith A W2 grease for sizes up to 5". Mobilith AW2 is a superior industrial grease with a lithium complex thickener and highly refined base oil. If this grease is not available, use a compatible grease with these features:

NLGI Grade 2  
Minimum dropping point 475 degrees  
750 SUS @ 100 degrees

Recommended Greases:

Mobilith AW2  
Mobilith SHC220  
Shell Alvania #2  
Texico Premium RB



## 5.6 Hydraulic system (REV. 08-06)

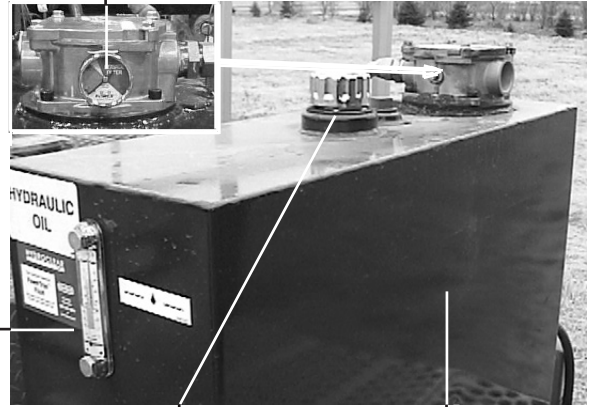


**CAUTION:** Lack of proper hydraulic oil level in the reservoir tank will cause system to heat under continuous running. Check the hydraulic oil level daily and replace as necessary.

The in tank hydraulic oil filters should be changed after the first 10 hours of operation. Change hydraulic oil and filters after the first 100 hours of operation. Thereafter, change hydraulic oil filters every 500 hours and change hydraulic oil and filters at least every 1000 hours of operation. Change the in tank oil filter if the oil filter pressure gauge indicates a plugged filter

Check the hydraulic oil regularly, and if the oil has a burnt smell or milky appearance, change it immediately.

oil filter pressure gauge



hydraulic oil temperature and level gauge

hydraulic oil fill cap

hydraulic reservoir



DuraTech Industries recommends using Cenex Qwiklift HTB if your machine has a Qwiklift decal on the hydraulic tank. Other acceptable fluids include Mobil 423, Farmland Super HTB, Conoco Hydroclear Power Tran Fluid or other similar fluids. If the hydraulic tank does not have this decal, then all of the above fluids are acceptable.





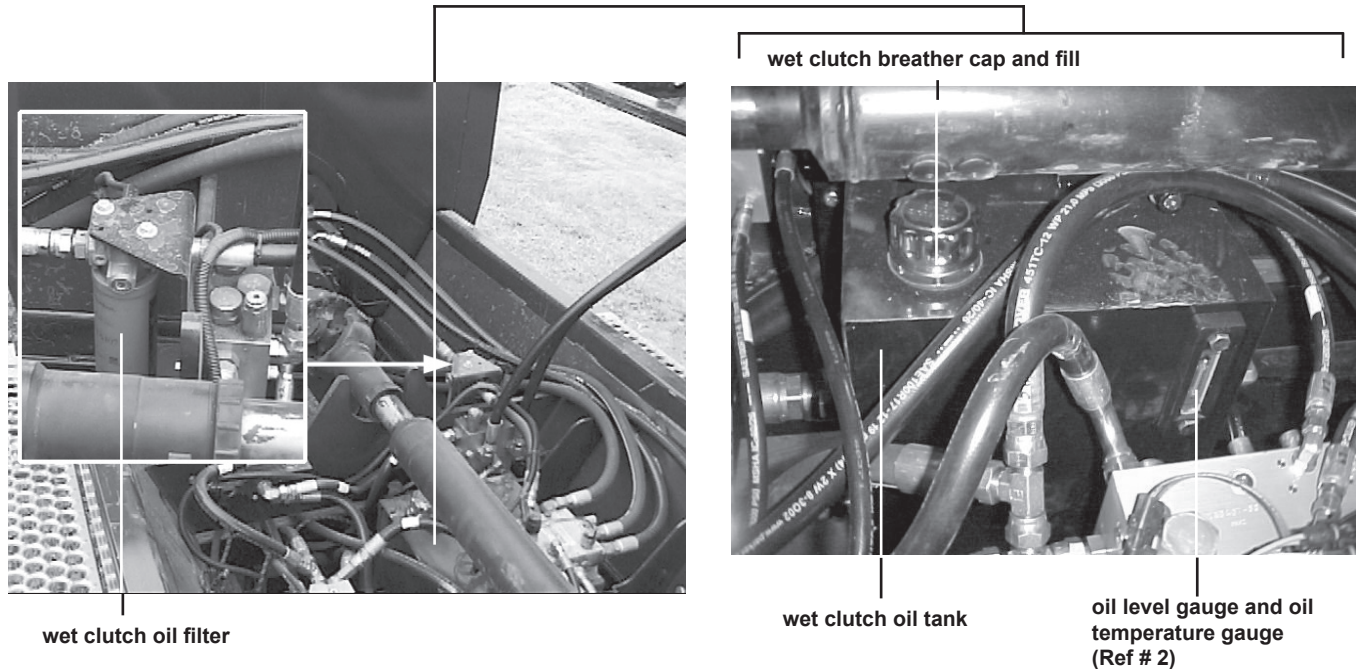
## 5.7 Wet clutch system (REV. 06-07)

Change the clutch oil after the first 100 hours of use. Thereafter, change the clutch oil, oil filter, and breather cap every 500 hours of use, annually, or if the oil color changes, whichever comes first.



**Note:** Drain cooler and tank when changing oil.

Change the oil filter (4400073) if the clutch is disengaged due to high oil pressure.



The clutch contains at least 15 gallons of oil. **Only the following oils are approved by PT TECH for use in the HPTO system.**

**Mobilfluid 424 is preferred oil of choice.**

**When the clutch will be operating in environmental conditions where the ambient air temperature is below 15 degrees F for extended periods of time, it is recommended by PT TECH that a cold climate oil be used.**

**Warm Climate Oils** (when ambient temperature is greater than 15 degrees F)

1. Mobilfluid 424
2. Caterpillar TDTO (SAE 30 ONLY)
3. Shell Donax TD (TD ONLY)
4. Vermeer VMF Ultra Gold



**Cold Climate Oils** (When ambient temperature is below 15 degrees F)

1. Mobilfluid 424
2. Caterpillar TDTO (10W ONLY)
3. Shell Donax TD low vis



**NOTE: DO NOT USE ANY OTHER OILS, OR CLUTCH LIFE WILL BE SHORTENED.**

**Wet clutch is to be serviced and inspected after 5000 hours of operation – contact your dealer for details.**

To locate retail oil sales locations in your local area, use the phone number provided below.

**Mobilfluid 424 or LT**

Phone: 1-800-662-4525

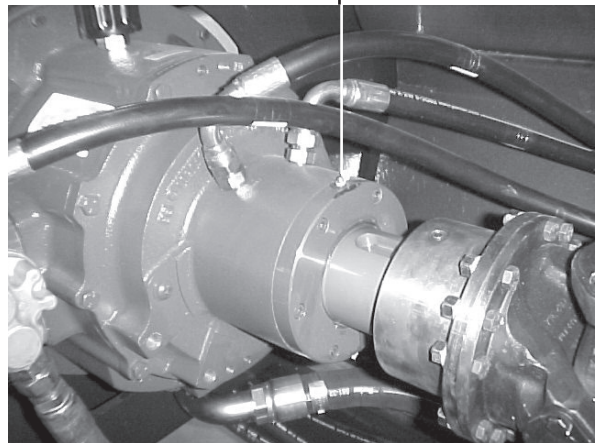
**Caterpillar TDTO SAE 30 or 10W**

Phone: 1-800-321-7332

**Shell Donax TD or TD Low Vis**

Phone: 1-800-231-6950

wet clutch lubrication zerk  
(1 top, 1 bottom)  
(Ref # 18)







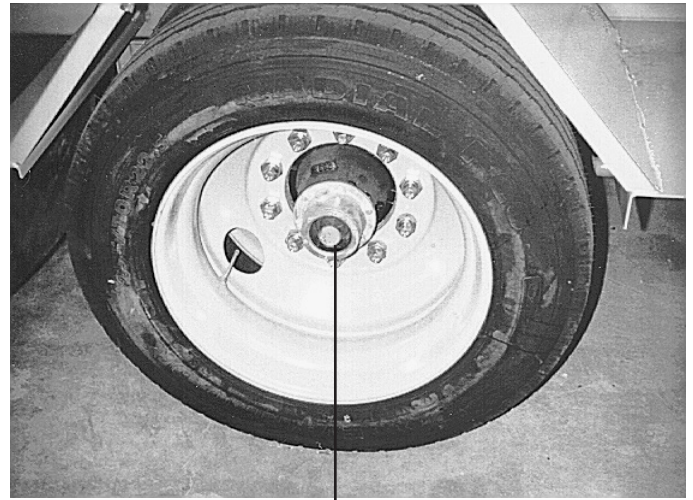
## 5.8 Axle, wheels and tires (REV. 01-03)

### TIRE PRESSURE

Set the tire pressure according to the manufacturer's specifications. The appropriate tire pressure can be found on the sidewall of the tire.

### WHEEL BEARINGS

The wheels have tapered roller bearings in an oil bath. Each hub is equipped with a transparent oil cap which has an oil level indicator mark that allows for easy checking of the oil level. The oil level should be checked daily during the pre-operation inspection. This lubrication method assures long bearing life with proper maintenance of the oil level. When adding or replacing oil in the wheel bearings, use SAE 80W-90 HYPOID GEAR OIL.



oil level indicator  
(Ref # 5)

### AIR BRAKES

The air brakes should be inspected periodically by a qualified air brake technician.

## 5.9 Brake component lubrication (REV. 01-03)



**CAUTION:** Care must be exercised when lubricating the camshaft bushings and anchor pins. Over lubrication could cause a safety problem as brake linings become saturated with lubricants.

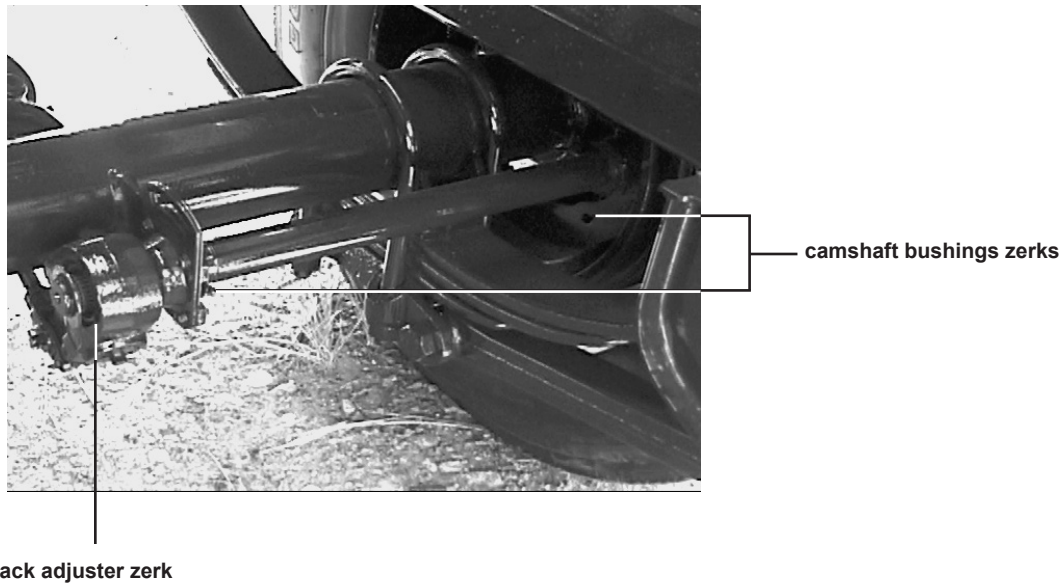


**NOTE:** When relined shoe linings become saturated with grease, replace with new shoe and lining assemblies.

A schedule for the periodic lubrication of brake components should be established by the operator on the basis of past experience and the severity of operating conditions.

### GUIDELINES

- **For camshaft roller journals:** Lubricate with high temperature anti-seize grease.
- **For anchor pins:** Lubricate with high temperature anti-seize grease.
- **For manual slack adjusters:** Lubricate with NLGI Grade 2.
- **For automatic slack adjusters:** Lubricate with ASA manufacturer's recommended lubricant.



## FREQUENCY OF SERVICE

Camshaft roller journals, anchor pins, slack adjusters every 25,000 to 30,000 miles or every six months depending on severity of operating conditions. (For off highway use: service every 4 months depending on severity of operating conditions)

## SUGGESTED PREVENTATIVE MAINTENANCE

- **Every 1,000 miles:** Check oil level in wheel hub and inspect wheel for leaks.
- **Every 15,000 miles:** Check brake adjustment. Repack wheel bearings (grease application).
- **Every 25,000 to 30,000 miles:** Check lining wear and estimate reline time. Inspect camshaft, camshaft spider bushing and camshaft support bracket bushing for any signs of wear. Lubricate brake actuating components.
- **Every 100,000 miles, once a year, or at brake reline:** Replace wheel bearing lubricating oil (if applicable). Check brake air chambers and slack adjusters. Inspect brake rollers, roller shafts, anchor pins and bushings and replace if necessary.





## 5.10 Rotor bearing installation (SN up to HJ3114) (REV. 04-11)



**WARNING:** To ensure the rotor is not unexpectedly started, turn off and lock out or tag the power sources before proceeding. Failure to observe these precautions could result in bodily injury.

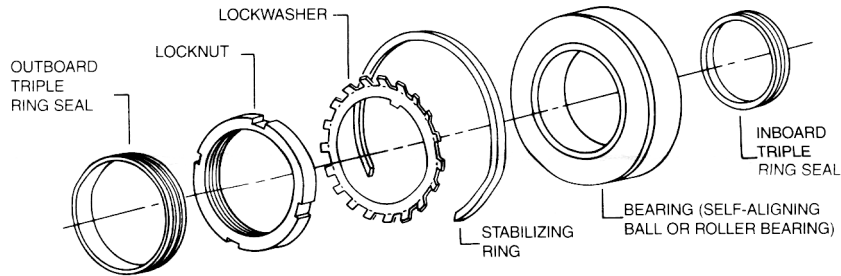


**NOTE:** Bearing housing caps and bases are not interchangeable and must be matched with mating half. Install the non-expansion bearing first.

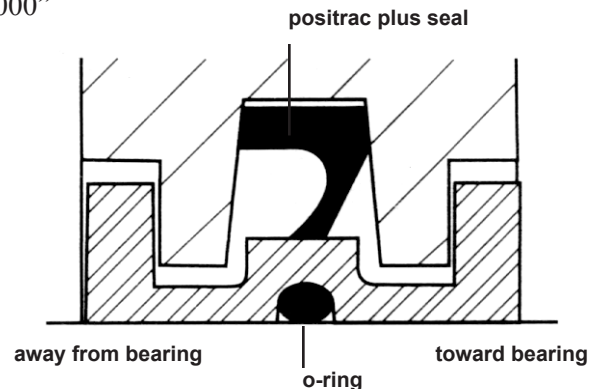


**NOTE:** Do not rotate bearing when the moving feeler gauge is between the roller and the outer ring.

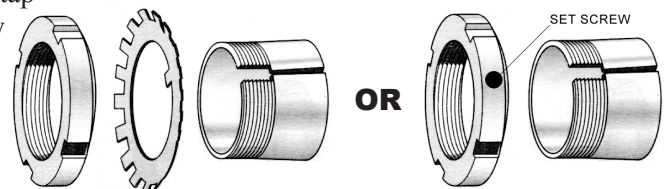
figure 5.8  
rotor bearing



1. Check shaft tolerance, the shaft should be 3.996" to 4.000"
2. Install inboard seal. Slide the seal onto the shaft. Resistance should only require slight hand pressure to overcome. The O-ring can be lubricated with grease or oil to ease assembly. Locate the seal to match the Labyrinths in the housing. The picture shows the PosiTrac Plus seal, which requires greasing the seal lip at assembly. Note the orientation of the seal, one way prevents oil leakage, the other way prevents dirt from entering the bearing. Assemble the seal to prevent dirt contamination (this means there will be a slight oil leakage around the seal).
3. Mount bearing on shaft.
  - a. For older bearings with a lock washer, screw off the locknut and remove the locking washer. For new bearings with a set screw, oil the set screw, tap with hammer to release the threads, and unscrew the locknut.

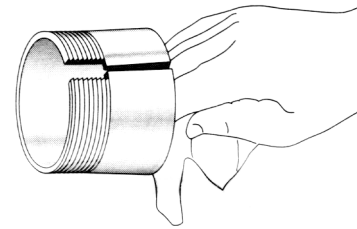


**NOTE:** There is only one way to correctly install the bearing. Refer to Figure 5.8 for illustration.

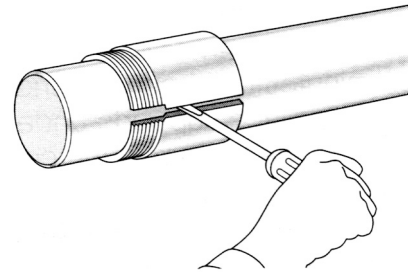




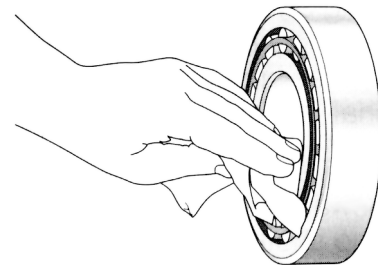
b. Wipe preservative from the surfaces of the sleeve and apply light oil to the sleeves outside diameter surface for easier bearing mounting and dismounting.



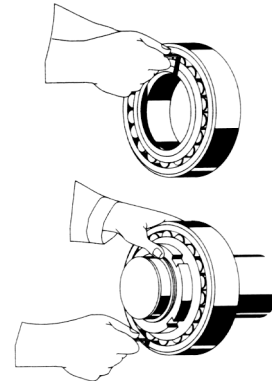
c. Open the sleeve by inserting a screwdriver in the slot, then position the adapter sleeve on the shaft, thread outward as indicated, to approximate location with respect to the required bearing centerline.



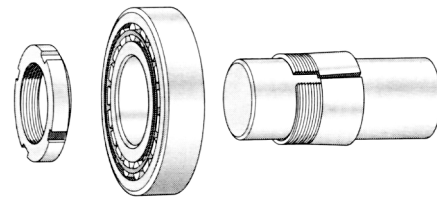
d. Wipe the preservative from the bore of the bearing and then oil the surface light. Use a thin mineral oil.



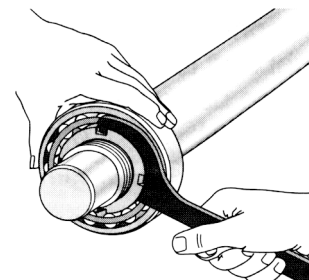
e. Measure the unmounted internal radial clearance in the bearing by inserting progressively larger feeler blades the full length of the roller between the most vertical unloaded roller and the outer sphere. Write this number down.



f. Place the bearing on the sleeve. Screw the nut with its chamfered face toward the bearing, but do not mount the lock washer. Do not push the inner ring up the taper of the sleeve.

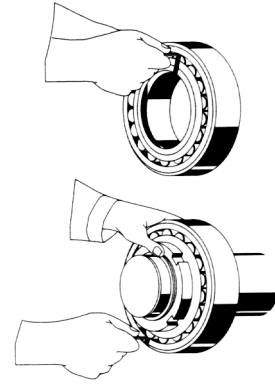


g. Turn the nut sufficiently to ensure that the shaft makes proper contact (self-locking) with the sleeve, continuing to drive the bearing up the sleeve.

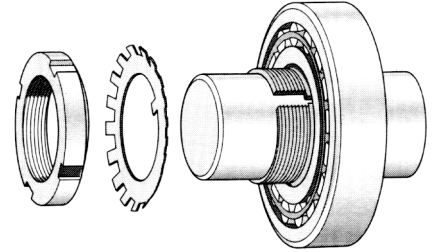




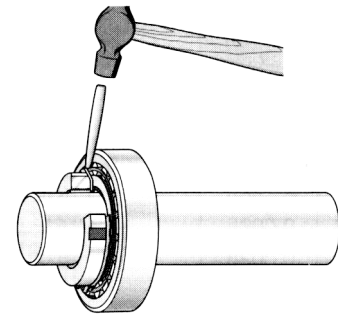
h. Check the mounted internal clearance until the bearing internal clearance has been reduced by 0.0020" to 0.0028" for the front bearings and 0.0039 to 0.0047 for the rear bearings (from step e).



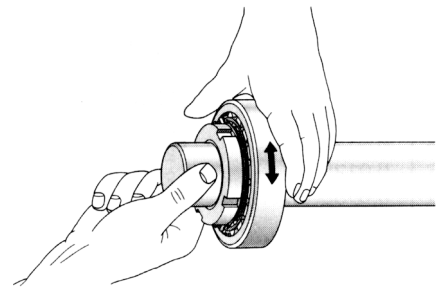
i. Unscrew the nut, placing the lock washer in position, and tighten the nut firmly again. Make sure that the bearing is not driven up the sleeve any further.



j. Lock the nut by bending one of the lock washer tabs down into one of the slots in the nut. Do not bend it to the bottom of the slot.



k. Check that the shaft or bearing can be turned easily by hand.





**NOTE:** Each cap must be matched with its mating lower half, as these parts are not interchangeable.

4. Install outboard seal. Again, watch orientation of seal, position the seal to prevent dirt from entering the bearing
5. Set lower halves of housings on base and lightly oil the bearing seats.

Place the shaft with bearings into the lower half of the housing, carefully guiding seals into the seal grooves. Be certain that the bearings' outer rings sit squarely in the pillow lock bearing seats.

Bolt the "fixed" housing securely in place (see step 6). The "free" bearing housing will be located and bolted to its mounting surface after properly positioning the bearing in the "free" housing to ensure correct float. Note: if shimming is required, shims must cover the entire mounting surface of the pillow block

6. A stabilizing ring is used for both bearings. The front bearing is a spherical roller bearing, and the addition of the stabilizing ring fixes its position. The rear bearing is a CARB (toroidal roller) bearing, and the outer race must be fixed (the rollers and inner race of this bearing is free to move axially with respect to the outer race). On both bearings, move the shaft axially so that the stabilizing ring can be inserted between the bearing outer race and housing shoulder on the locknut side of the bearing.
7. The bearing seat on the upper half of the housing (cap) should be checked for burrs, thoroughly cleaned, lightly oiled, and placed over the bearing. With oil lubrication, use a sealing compound such as Permatex 2 or equivalent at the split surfaces, applying sparingly. Wipe a thin film near the outer edges. Excessive amounts of sealing compound will be forced out and also between the housing bore and bearing outside diameter. This can interfere with the outer race of the bearing, and make a "free" bearing "fixed". The two dowel pins will align the upper half of the housing to its mating base.



**NOTE:** Caps and bases of pillow blocks are not interchangeable. Each cap and base must be assembled with its original mating part. The housings are marked with serialized adhesive labels on the cap and base to assist in assembling of mating parts.

Lock washers and cap bolts are then applied and tightened to 380 ft lbs to complete the assembly.



## 5.10a Dodge Rotor bearing installation (SN IJ3115 & up) (REV. 04-11)



**WARNING:** To ensure the rotor is not unexpectedly started, turn off and lock out or tag the power sources before proceeding. Failure to observe these precautions could result in bodily injury.



**NOTE:** Bearing housing caps and bases are not interchangeable and must be matched with mating half. Install the non-expansion bearing first.

### Instruction Manual For IMPERIAL Adapter Mounted DODGE ISAF

#### Pillow Blocks and IP Unitized Spherical Roller Bearing Pillow Blocks, Flanges, Piloted Flanges & Take Ups

### GENERAL INFORMATION

DODGE ISAF and IP Spherical Roller Bearing mounted units incorporate a unique way of seating, mounting, and dismounting the unit to and from the shaft. The patented sealing system (Pat. #5,908,249) has proven effective in protecting the internal bearing components, due to its constant pressure, while suit allowing a full + or 1 degree of misalignment.. The patented IMPERIAL system (Pat. #5,489.156) pulls the bearing on the adapter based upon a predetermined clockwise rotation of the locknut. Dismounting is accomplished via counterclockwise rotation of the locknut Keep in mind that the thread on the locknut as well as on the adapter is a left hand thread.



**WARNING:** To ensure that drive is not unexpectedly started, turn off and lock out or tog power source before proceeding. Failure to observe these precautions could result in bodily Injury.

### INSPECTION

Inspect shaft Ensure that the shaft is smooth, straight, clean, and within commercial tolerance Inspect unit. Do not allow unit to be exposed to any dirt or moisture.



Keep weight off bearing during mounting via a sling or jacks



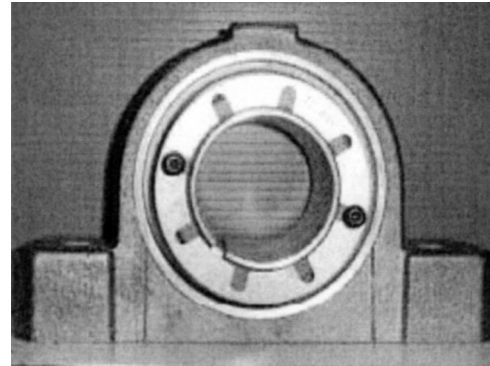
**WARNING:** Because of the possible danger to persons(s) or property from accidents which may result from the improper use of products, it is important that correct procedures be followed. Products must be used in accordance with the engineering information specified in the catalog. Proper installation, maintenance and operation procedures must be observed. The instructions in the instruction manuals must be followed. Inspections should be made as necessary to assure safe operation under prevailing conditions. Proper guards and other suitable safety devices or procedures as may be desirable or as may be specified in safety codes should be provided. and are neither provided by Baldor Electric nor are the responsibility of Baldor Electric. This Unit and its associated equipment must be installed, adjusted and maintained by qualified personnel who are familiar with the construction and operation of all equipment in the system and the potential hazards involved.



## MOUNTING

Install the non expansion unit first.

1. Apply a coating of light oil or other rust inhibitor to the adapter area of the shaft.
2. Before mounting bearing to shaft, remove lockplate from bearing and turn locknut counterclockwise one to two turns to allow adapter to expand fully. The unit is now shaft ready. Slide the bearing to the desire position on the shaft.



Picture 1

3. Proper locking of this unit to the shaft is based on turning the locknut clockwise a predetermined number of degrees shown for each bore size on Table 1. The turning of the locknut must start from a “ZERO reference point.” This “ZERO reference point’ is defined as the point when the clearance between adapter sleeve, shaft and bearing bore has been removed, and all surfaces are in metal to metal contact

- 3A. To reach the ‘ZERO Reference Point,’ rotate locknut clockwise, using both hands, as tight as possible. When mounting bearings with shaft sizes 3 15/16” and larger the following TEST must be performed. *As a test to insure you have reached the “ZERO Reference Point” tap on the face of the nut with a hammer and attempt to rotate the nut using both hands. If the nut will not rotate then you have reached the ‘ZERO Reference Point’ and you should proceed to step 4. if you can rotate the nut, using both hands, then you have not reached the true ‘ZERO Reference Point,” and should repeat step 3A until ‘ZERO Reference Point” is obtained.*

SHAFT SIZE	BASIC BRG NO.	LOCKNUT ROTATION	
		DEGREES	TURNS
1 1/8 - 1 1/2	22208K	280 +/- 25	3/4 to 7/8 turn
1 5/8 - 1 3/4	22209K	330 +/- 25	7/8 to 1 turn
1 7/8 - 2	22210K	330 +/- 25	7/8 to 1 turn
2 3/16 - 2 1/4	22211K	405 +/- 40	1 to 1-1/4 turns
2 3/8 - 2 1/2	22213K	405 +/- 40	1 to 1-1/4 turns
2 11/16 - 3	22215K	405 +/- 40	1 to 1-1/4 turns
3 3/16 - 3 1/2	22218K	495 +/- 40	1-1/4 to 1-1/2 turns
3 11/16 - 4	22220K	495 +/- 40	1-1/4 to 1-1/2 turn
4 7/16 - 4 1/2	22222K	450 +/- 40	1-1/8 to 1-3/8 turns
4 15/16 - 5	22226K	540 +/- 40	1-3/8 to 1-5/8 turns
5 7/16 - 5 1/2	22228K	540 +/- 40	1-3/8 to 1-5/8 turn
5 15/16 - 6	22232K	405 +/- 40	1 to 1-1/4 turns
6 7/16 - 7	22236K	450 +/- 40	1-1/8 to 1-3/8 turns

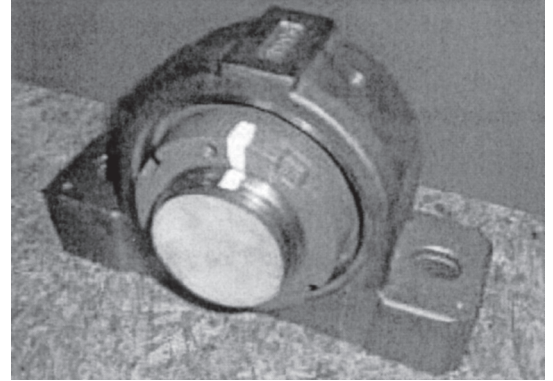


**NOTE:** All Weight Must Be Removed From The Bearing When Obtaining The “ZERO Reference Point.”



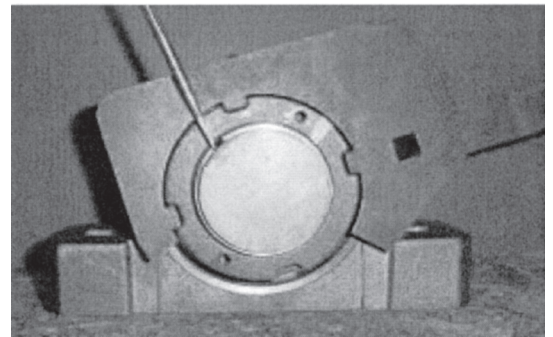


4. Once “ZERO reference point” is reached, scribe a line through both locknut face and adapter face (Picture 2). Then continue to tighten the locknut (Picture 3) by turning it clockwise using hammer and drift or spanner by the appropriate rotation angle shown on Table 1. Proper mounting has been achieved when the scribed line on the locknut has rotated from the scribed line on the adapter face by the angle shown on Table 1. To reach the full rotation of the locknut, the use of hammer blows onto spanner or drift may be needed for proper mounting. Rotate nut 1-5/8 turns.



Picture 2

5. a) Slide lockplate over shaft and align tang of lockplate with slot in adapter sleeve.  
 b) Find a locknut hole that aligns with a lockplate hole. If the closest locknut hole is beyond a lockplate hole, then tighten, not loosen, the locknut to meet a lockplate hole  
 c) Insert lockwasher and tighten button head screws to lock assembly. (Ref. Picture 4)
6. Bolt down pillow block or flange unit to the structure.



Picture 3

7. Repeat steps 1 through 6 for the expansion bearing except immediately after Step 2 do the following:

### EXPANSION

#### Pillow Blocks (Locknut facing outboard)

Align pillow block housing mounting holes with substructure mounting holes. Push insert as far as possible in the direction of the fixed bearing. If bearing locknut is facing toward fixed bearing, position float bearing insert in center of housing.

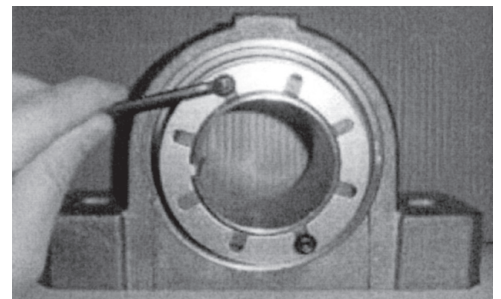


**NOTE:** This is necessary because in the process of mounting, bearing is being drawn toward locknut. **Also remember to keep weight off of bearing.**



**NOTE:** Use hardened washers and properly torqued bolts to obtain sufficient clamp force between the bearing block and the mounting structure.

Picture 4





**ISAF:**

For 2 Bolt and 4 Bolt Pillow Blocks: 1) Remove bearing cap 2) Remove stabilizing ring; 3) Reassemble cap on base, 4) Torque cap bolts to recommended torque values. (Table 2)

**DISMOUNTING**

1. Remove weight off bearing via a sling or jacks.
2. Remove mounting bolts from bearing.
3. Remove button head screws and lockplate from the adapter nut.
4. Using a spanner wrench turn the locknut counterclockwise until the bearing unit is Pushed off the adapter sleeve sufficiently to permit the release of the adapter sleeve from the shaft.

**TABLE 2 - Cap Bolt Torque for ISAF Pillow Blocks  
(Non-Expansion & Expansion) (Grade 5 Bolts)**

Bore Size (In.)	2 Bolt Base		4 Bolt Base	
	Bolt Size	Torque Ft. - Lbs.	Torque Bolt Size	Ft-Lbs.
1-7/16- 111/16	3/8-16	24-30	-	-
1-15/16-23/16	7/16-14	40-50	-	-
2-7/16-21/2	1/2-13	60-75	1/2-13	60-75
2-11/16-3	5/8-11	120-150	5/8-11	120-150
3-7/16-31/2	3/4-10	208-260	3/4-10	208-260
3-15/16-4	-	-	3/4-10	208-260
4-7/16-31/2	-	-	7/8-9	344-430
4-15/16-5	-	-	1-8	512-640
5-7/16-51/2	-	-	1-8	512-640
5-15/16-6	-	-	1-8	512-640
6-7/16-61/2	-	-	1-8	512-640
6-15/16-7	-	-	1-8	512-640

Bore Size	Total Expansion (In.)	
	IP	ISAF
11/8 - 11/2	3/16	7/32
15/8 -17/8	1/4	7/32
115/16 - 2	1/4	17/64
213/16	1/4	7/32
21/4 - 27/16	1/4	5/16
21/2 - 33/16	1/4	15/64
31/4 - 31/2	1/4	3/8
311/16 - 4	5/16	3/8
47/16 - 5	3/8	3/8
57/16 - 7	N/A	3/8



## 5.11 Hammermill maintenance (REV. 01-03)

Visually examine the mill to see if any of the internal parts show excessive wear. These parts should include liners, rotor discs and the holes in the discs that support the rods. Enlarged holes can cause rods to break or bend. Also check rods, rod locking or retaining devices, hammers, screens, screen tracks and hold downs, main shaft, platform locking devices, hinges or anything else that could wear and perhaps fail and causing damage to the hammermill and/or personnel if not properly maintained. The bearings and motor alignment should also be checked along with mounting bolts to insure a firm foundation and reduced vibration.



**CAUTION:** Keep all foreign objects out of the tub and away from the mill. Foreign objects may result in personal injury or damage to the machine.

The hammers are designed to grind products such as wood waste, green waste, construction and demolition debris, tree branches and trunks, compostables and mulch that may be reduced in size in a hammermill. The hammers are not designed to grind or crush hard materials such as coal, minerals, metals, rock, or other incompressibles, which will cause parts to fail. These materials must never be allowed to enter a hammermill.

The hammers have been designed and manufactured to provide the best compromise between hardness for good wearing qualities and strength for dependability and resistance to breakage.



**WARNING:** The hammers have been heat treated, and any alteration of the hammers by heating, grinding, resurfacing or any other process can change the mechanical properties of the hammer and make it unsuitable or dangerous to use.

Because of the high capacity of the machine, the hammers will wear and must be considered expendable. Each fixed hammer has two (2) cutting edges and each swing hammer has two (2) cutting edges. For maximum life, it is suggested that hammers be rotated periodically to even out the wear over the entire rotor. If one end of a hammer is allowed to wear too long, one of the hammer's cutting edges will be lost.

Screens also have two (2) cutting edges. When cutting edges become rounded, the screen can be turned end for end exposing the new cutting edges. The results of badly worn hammers and screens is loss of capacity, and added horse power requirements.

Hammer rods are case hardened to maximize wearability and toughness, although hammer rods must be considered expendable.



**NOTE:** Hammer and hammer rod life can be extended by keeping rotor rotating at 2000 RPM. Over powering or over feeding the rotor will cause the swinging hammers to lay back resulting in excessive wear on both the hammers and the rods.



## 5.12 Fixed hammer maintenance and replacement (REV. 06-19)



**CAUTION:** Disengage the driveline clutch. Shut off the engine. Remove the key before working on the rotor.



**IMPORTANT:** The bolts on the hammer tips should be checked periodically for proper torque. Torque ratings for two bolt tips are listed below.

When replacing hammer tips, We recommend the following:

- A. Always replace fixed hammer tips in pairs, 180 degrees apart (same as with the swinging hammers, illustrations A & B figure 5.9).
- B. Tips placed 180 degrees apart should be the same weight.
- C. When starting the hammermill after installing a new set of tips or after turning the tips to expose new faces, watch for unusual or excessive vibration. If any is noticed, shut off the hammermill. Determine the cause and correct it before starting the mill again.

To replace the hammer tips on machines with fixed hammers, perform the following steps:

1. Be sure to disengage the clutch, shut down the engine, and remove the key.
2. Identify the tips to be removed, then loosen and remove the bolts and tips.
3. Rotate or replace tips. Use new bolts and lock nuts when replacing tips.
4. **FIXED HAMMER TORQUE SPECIFICATIONS**

For two-bolt tips with 5/8" NF grade 8 bolts and grade 8 lock nut, Torque to 190-210 ft.lbs (26-29 kg-m).

For one-bolt tips with 7/8" NF grade 9 bolts and grade 9 toplock bolts, Torque to 509 ft. lbs (70 kg-m).

5. After 2 hours of grinding, retighten the bolts to the same torque values.
6. Periodically retighten the bolts to the same torque values.



## 5.13 Swinging hammer replacement and maintenance (REV. 04-03)



**CAUTION:** Disengage the wet clutch, shut off the engine and remove the key before working on the rotor.

When installing or changing hammers, be sure to follow the hammer diagram carefully. Misplacement of the hammers could cause excessive vibration. We recommend that hammers be balanced in sets according to the rod on which they are to be installed. Sets of equal weight should be installed 180 degrees apart (See Illustration A). When replacing a worn or broken hammer with a new hammer always install a second new hammer 180° away from the first (see Illustration B). When starting the hammermill after installing a new set of hammers or turning corners, watch for unusual or excessive vibration. If any occurs, immediately shut off the mill. Determine the cause and correct it before starting the mill again.

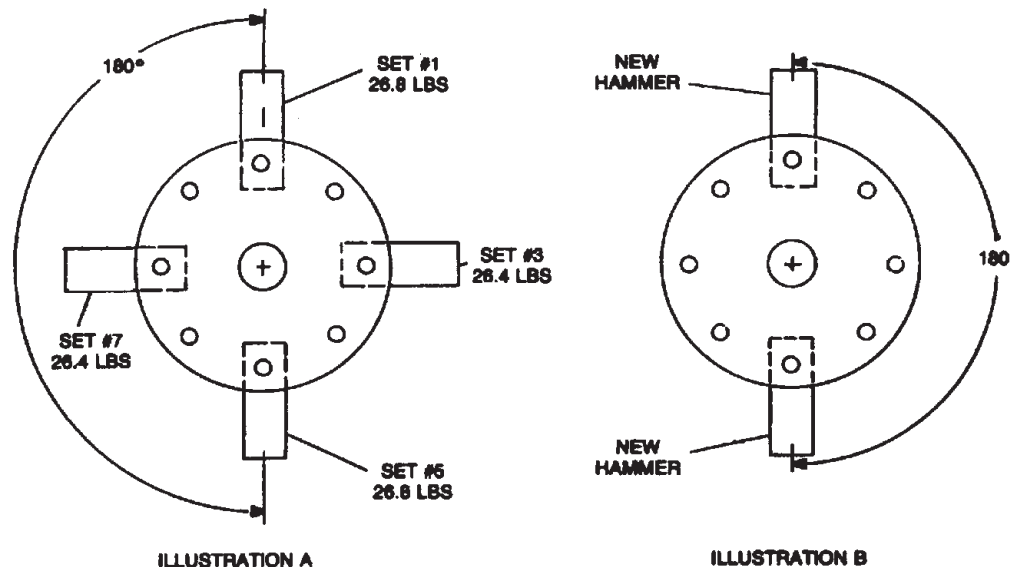
To replace worn hammers on machines with swinging hammers, perform the following steps:

1. Follow the normal shutdown procedure which can be found in section 3.6 of this manual.
2. Loosen the four bolts at the front of the rotor which holds the hammer rod retainer plate in place.
3. Rotate the retainer plate to align holes allowing the hammer rods to be removed through the front of rotor.
4. Remove one row of hammers and replace individual hammers as necessary. Note the location of any spacers. See hammer spacing charts.
5. After all the hammers have been replaced, rotate the retainer plate to lock hammer rods in place, and tighten the four retainer plate bolts.



**IMPORTANT:** Care should be exercised when replacing only a few hammers and not the entire set. If one or more new hammers are inserted on a rod, the same number of new hammers should be inserted on the rod directly across the rotor. This will maintain a balanced rotor for vibration free operation.

figure 5.9  
hammer replacement  
illustrations A + B

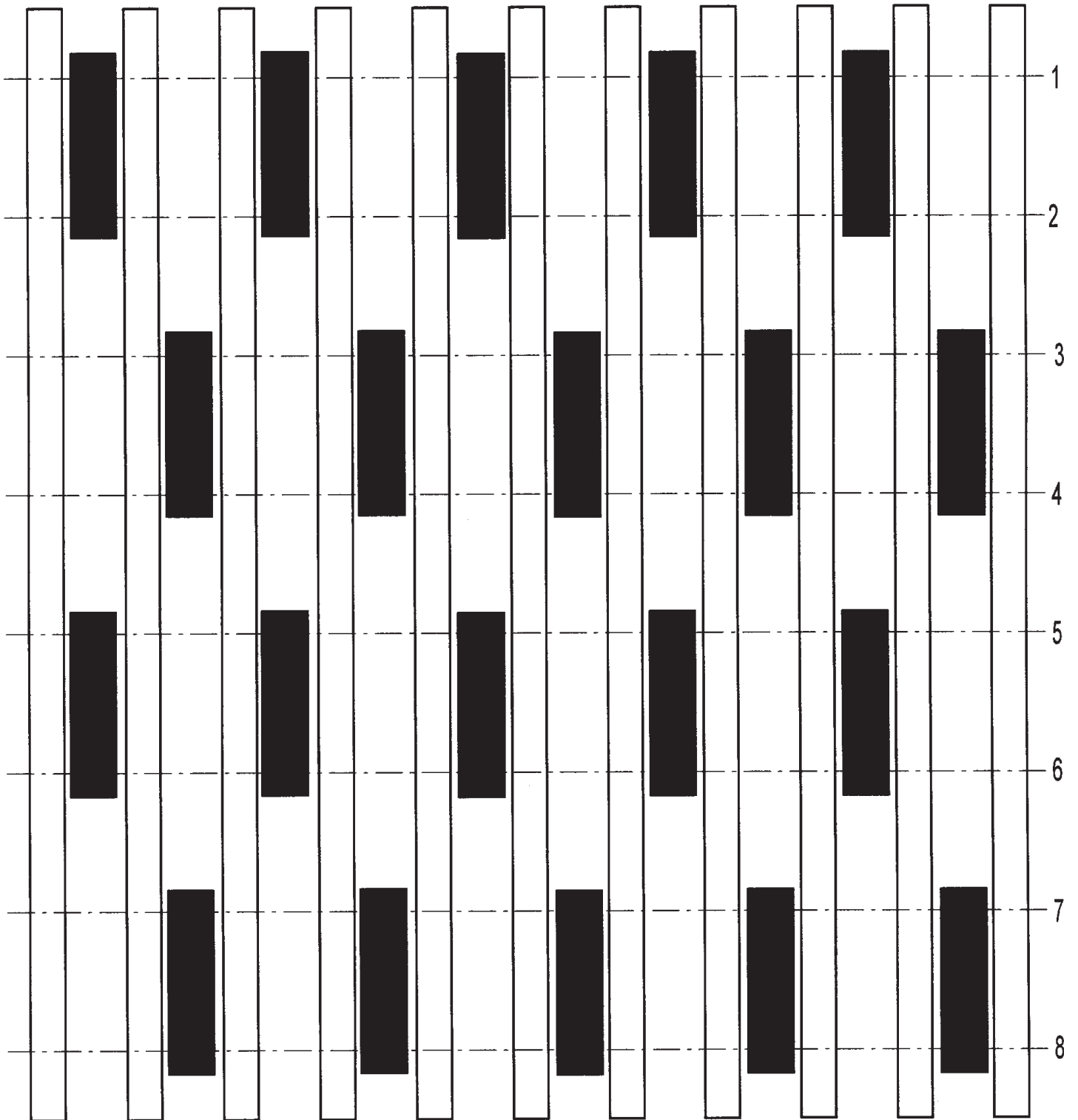




FIXED HAMMERS SPACING CHART

FRONT OF ROTOR  
←

20 FIXED HAMMERS REQUIRED

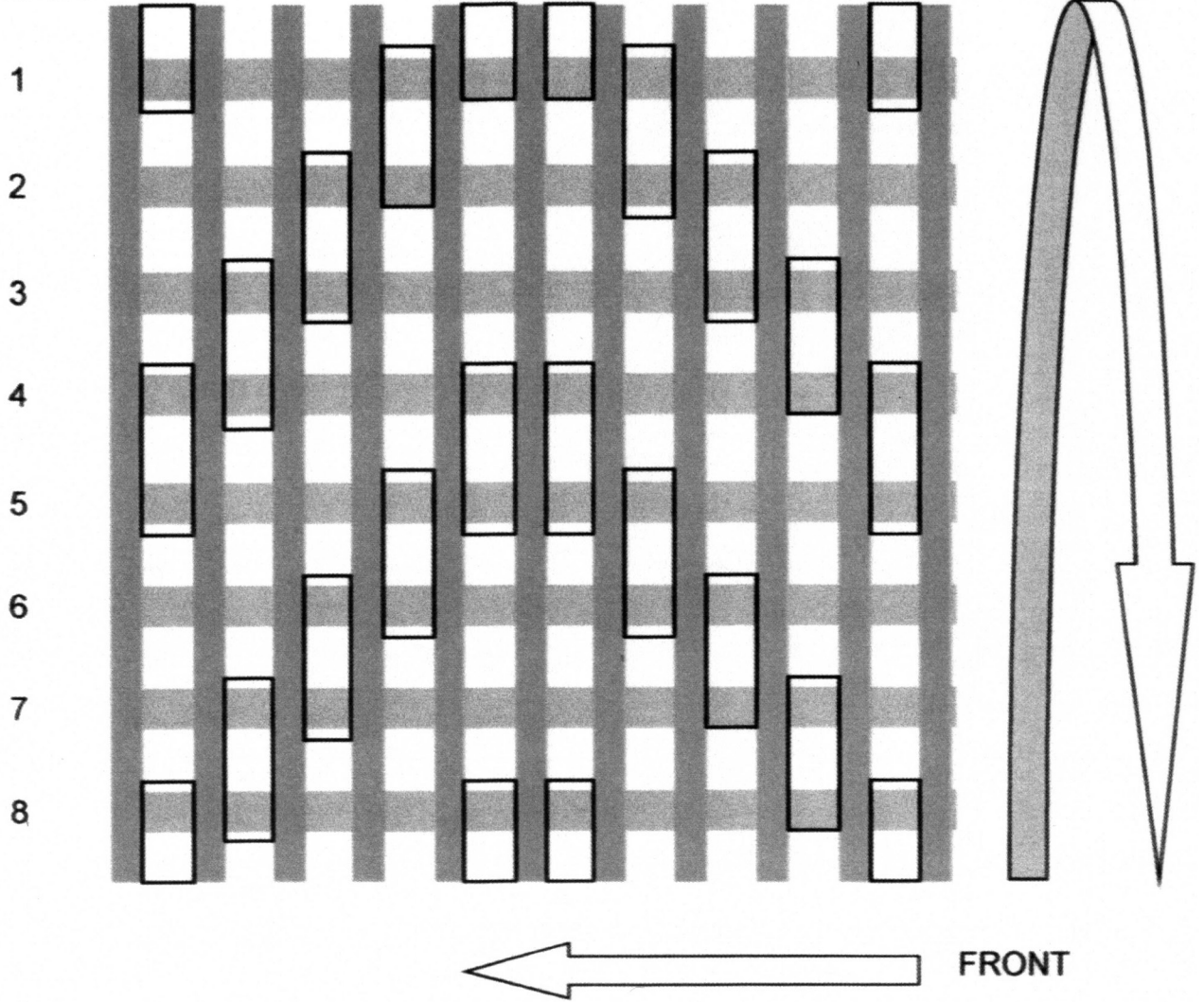






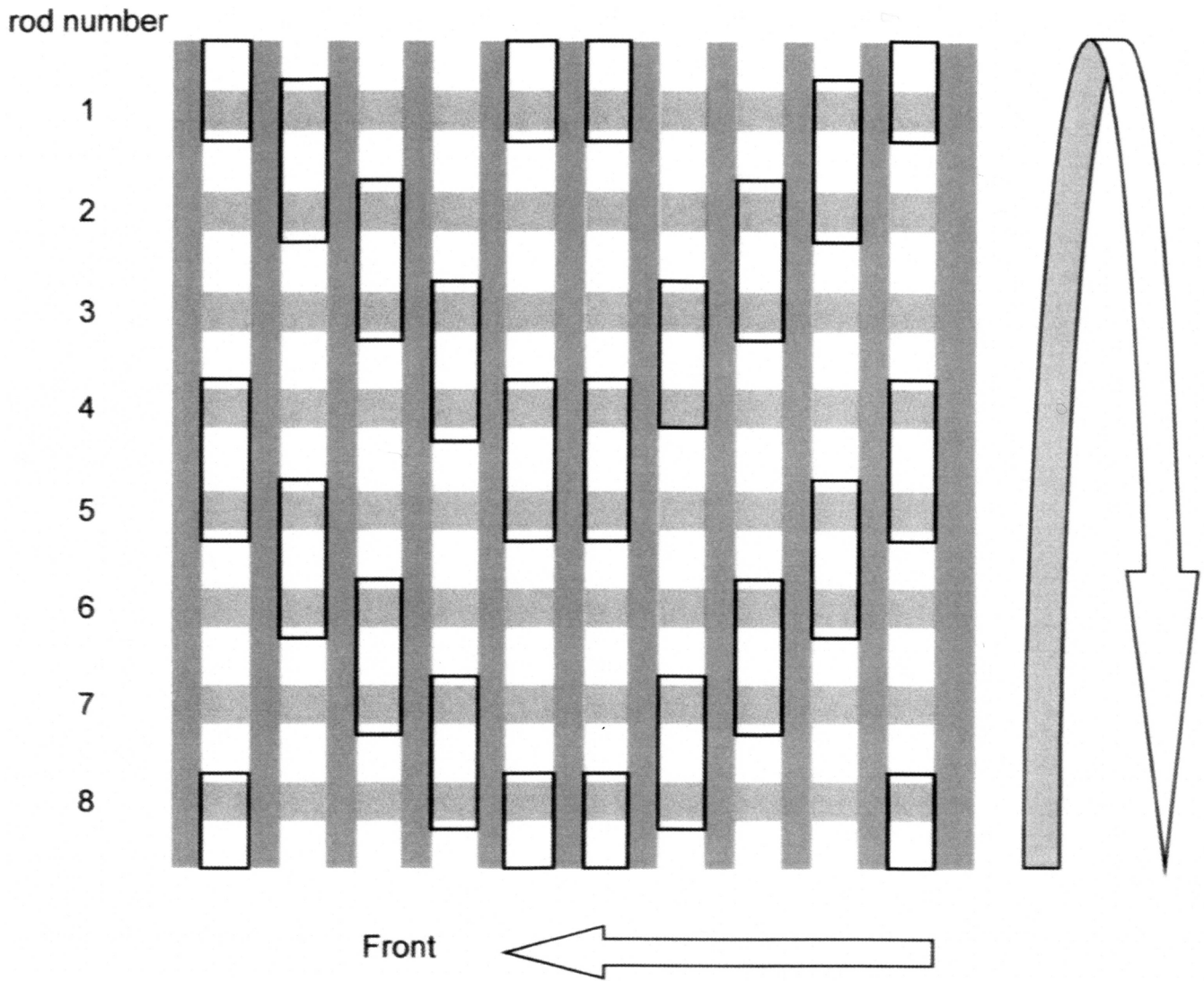
FIXED V HAMMER PATTERN

rod number



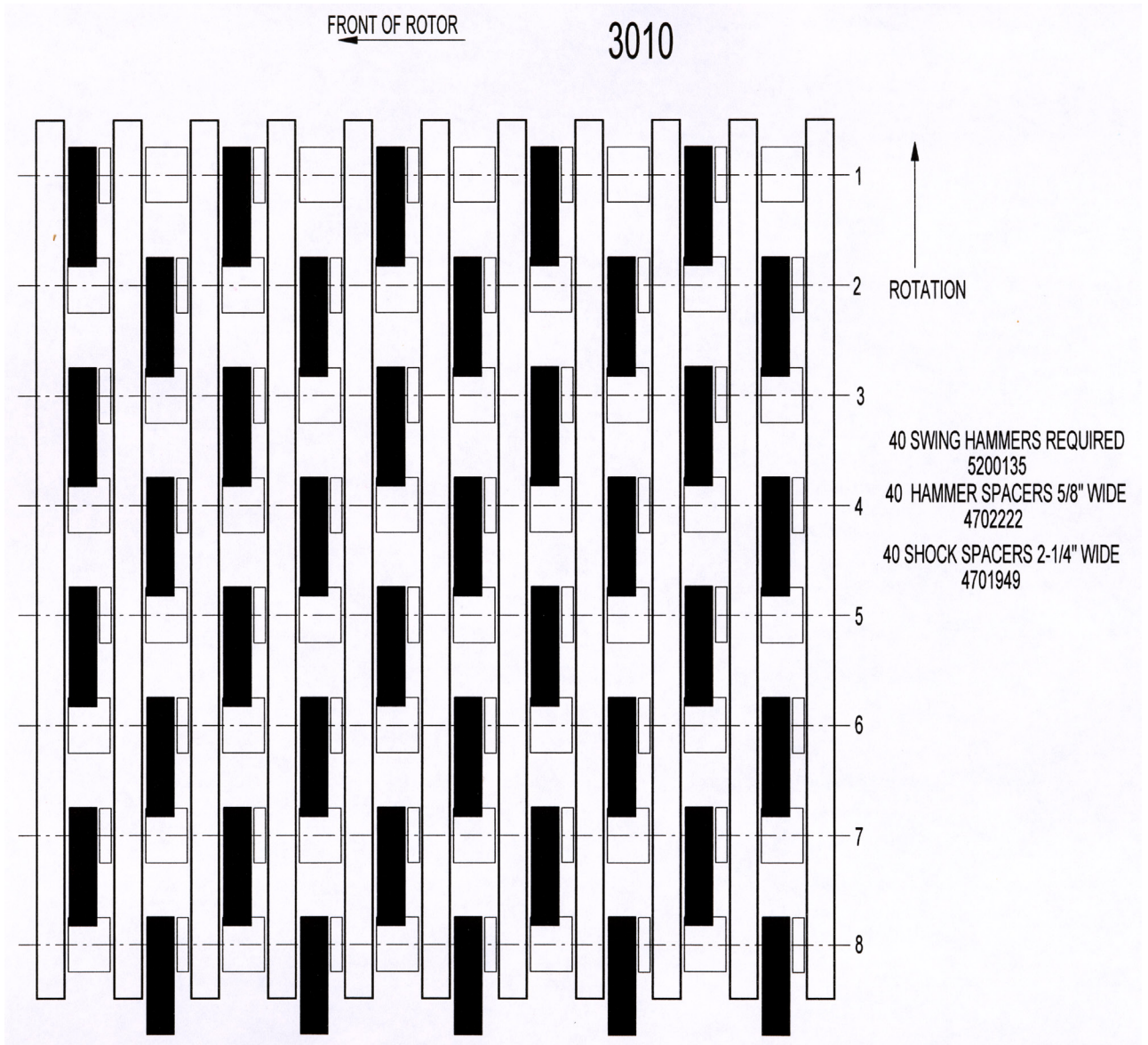


FIXED REVERSE V HAMMER PATTERN





### SWINGING HAMMERS SPACING CHART







# Section 6: Troubleshooting the 3010 DURATECH TUB GRINDER

## 6.1 Troubleshooting the electronic governor system (REV. 01-03)

1. When power is reaching the electronic governor the fuse light should be on. If this light fails to go on, check the fuse, the battery connections, the wiring harness, and the indicator lamp. If the fuse light is on, the wiring harness, battery connections, fuse and bulb are functioning correctly.
2. Check the TUB MODE operation of the electronic governor. With the engine and hydraulic systems at operating temperature, and the tub drive control valve in the forward position, throttle the engine up to 1800-2000 RPM.

With the mode switch in the tub position, the tub should be rotating. The speed of the tub can be varied by rotating the tub limit knob. The number of tub speed lights which are lit will vary with the setting of the tub limit knob.

If the number of tub speed lights lit varies as you rotate the tub limit knob, the manual portion of the controls are functioning correctly. Proceed to step 3.

If the manual portion is not working properly, proceed to trouble shooting table 6.1.

**table 6.1**  
troubleshooting the electronic governor in tub mode

PROBLEM	CAUSE	REMEDY
1. The tub does not rotate but the electronic governor and the manual hydraulic valve are working properly. There is pressure to the orbit motor.	<ol style="list-style-type: none"> <li>1. The tub is binding.</li> <li>2. There is too much material in tub.</li> <li>3. The tub is overloaded due to wet or tough grinding material.</li> <li>4. The pressure relief valve in the control valve set too low or is faulty.</li> </ol>	<ol style="list-style-type: none"> <li>1. Remove the material causing problem.</li> <li>2. Reduce the amount of material in the tub.</li> <li>3. Check oil pressure.</li> </ol>
2. The tub does not rotate, but the valve is receiving 18 to 24 volts of DC power. There is no pressure to the orbit motor. Note: The valve refers to the valve where you disconnect the wiring harness. For more information see "Electronic governor hardware test" later in this section.	<ol style="list-style-type: none"> <li>1. The electric hydraulic valve (forward/reverse) is not engaged.</li> <li>2. The valve assembly is dirty or faulty.</li> <li>3. The solenoid is faulty.</li> </ol>	<ol style="list-style-type: none"> <li>1. Engage the electric hydraulic valve.</li> <li>2. Clean or replace the valve assembly.</li> <li>3. Test the solenoid and replace as necessary.</li> </ol>
3. The tub does not rotate, and there is no voltage to the valve.	<ol style="list-style-type: none"> <li>1. There is no power to the electronic governor.               <ol style="list-style-type: none"> <li>a. The electronic governor is switched off.</li> <li>b. The fuse is blown.</li> <li>c. The tub limit knob is set fully counterclockwise.</li> </ol> </li> <li>2. A wire in the wiring harness is broken.</li> <li>3. The electronic governor is faulty.</li> </ol>	<ol style="list-style-type: none"> <li>1.               <ol style="list-style-type: none"> <li>a. Switch the electronic governor mode switch to tub.</li> <li>b. Replace the fuse.</li> <li>c. Turn the tub speed knob clockwise.</li> </ol> </li> <li>2. Replace or repair the wiring harness.</li> <li>3. Replace the electronic governor.</li> </ol>
4. The tub runs with the electronic governor switch off. Disconnect the wiring harness at the valve. A. If the tub stops B. If the tub keeps turning	<ol style="list-style-type: none"> <li>1A. The electronic governor is out of adjustment.</li> <li>2A. The electronic governor is faulty.</li> <li>1B. The valve override screw is adjusted in too far.</li> <li>2B. The valve is faulty.</li> </ol>	<ol style="list-style-type: none"> <li>1.A. Readjust the electronic governor.</li> <li>2.A. Replace electronic governor.</li> <li>1.B. Adjust the override screw.</li> <li>2.B. Replace the valve.</li> </ol>
5. The tub speed can not be varied with the tub limit knob.	<ol style="list-style-type: none"> <li>1. Valve override is adjusted in too far.</li> <li>2. The valve is stuck.</li> <li>3. The solenoid is stuck.</li> <li>4. The electronic governor is faulty.</li> </ol>	<ol style="list-style-type: none"> <li>1. Adjust the override screw.</li> <li>2. Clean or replace the valve assembly.</li> <li>3. Test the solenoid and replace as necessary.</li> <li>4. Replace the electronic governor.</li> </ol>



3. Checking the ENGINE MODE operation of the electronic governor. If the tub mode controls function correctly after following the tub mode trouble shooting check list, then follow the calibration instructions on page 28 of this manual. If the tub will not rotate, proceed to trouble shooting table 6.2.

**Table 6.2**  
troubleshooting the  
electronic governor's  
engine mode

<b>PROBLEM</b>	<b>CAUSE</b>	<b>REMEDY</b>
The tub will not rotate, and the sensor light is not lit.	<ol style="list-style-type: none"><li>1. The sensor gap is out of adjustment.</li><li>2. There is a broken wire on the wiring harness.</li><li>3. The sensor is faulty.</li><li>4. The electronic governor is faulty.</li></ol>	<ol style="list-style-type: none"><li>1. Readjust the sensor gap to 3/32". This is roughly the thickness of a nickel.</li><li>2. Repair or replace the wiring harness.</li><li>3. Test and replace the sensor as necessary.</li><li>4. Replace the electronic governor.</li></ol>
The tub will not rotate, and the sensor light is lit.	<ol style="list-style-type: none"><li>1. The tub limit knob is turned fully counterclockwise.</li><li>2. The electric hydraulic valve (forward/reverse) is in the neutral position.</li><li>3. The electronic governor is faulty.</li></ol>	<ol style="list-style-type: none"><li>1. Adjust the limit knob clockwise.</li><li>2. Engage the electric hydraulic valve.</li><li>3. Replace the electronic governor.</li></ol>

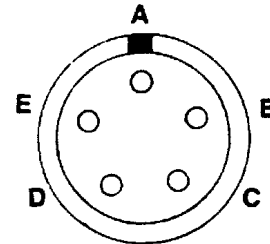


## ELECTRONIC GOVERNOR HARDWARE TEST



**NOTE:** 3010 DURATECH TUB GRINDERS contain 24 volt systems.

1. Power source: 24 volts DC  
Red wire + positive pin A wiring harness  
Black wire - Negative Pin B wiring harness
2. Test output voltage to valve DC  
Red wire + positive pin D wiring harness.  
Black wire - negative pin E. wiring harness.



**A - 24 volts DC ignition**  
**B - Ground**  
**C - Digital sensor signal\***  
**D - 0 to 24 volts ( + ) to valve**  
**E - 0 ( - ) to valve**

Test the electronic governor with power supplied to the governor control box and the mode switch set to the tub position. The grinder does not need to be running for this test. Disconnect the wiring harness at the valve. With a voltmeter set for 24 volts DC, connect the red lead of the voltmeter to the red lead of the wiring harness and black lead to the black wire. Turn the tub limit knob until the left speed light (turtle) is on. The voltmeter should read approximately 6 volts. Turn the tub limit knob clockwise. As more speed lights light up, the voltage should increase. Turn the knob until the right speed light (Rabbit) is lit. The volt meter should now read a minimum of 18 volts.

3. Output voltage of sensor AC  
red wire - Pin C wiring harness  
Black wire - Pin B wiring harness.

Set the sensor gap to 3/32".

Remove the wiring harness from the electronic governor.

With the engine at operating temperature and the clutch engaged, throttle the engine up to the desired engine RPM.

With volt meter set to AC volts, connect leads to pins B and C. The volt meter should read 2 to 3 volts AC .





## ELECTROHYDRAULIC VALVE COIL TEST

See the figure 7.3 for the location of the electro-hydraulic valve coil.

This test requires an accurate ohm meter. Disconnect the wiring harness leads at the valve coil. Set the meter to read ohms. Place one test lead from the meter on each of the two electrical connections of the valve coil. The reading should be 39-44 ohms for 24 Volt machines. If the reading is not in this range, replace the coil.

## MANUAL OVERRIDE

NOTE: If there is an electrical failure with the machine, it may still be able to grind. Switch the electronic governor off. Remove the rubber end cap and loosen the jam nut on the electro-hydraulic valve. Start the machine and engage the tub drive.

figure 7.2  
electronic governor system

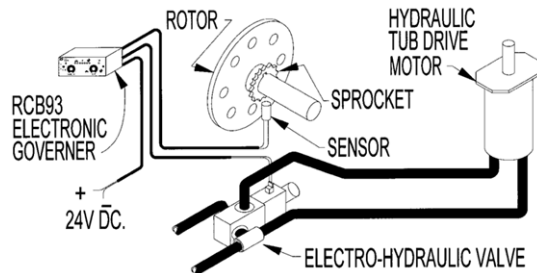
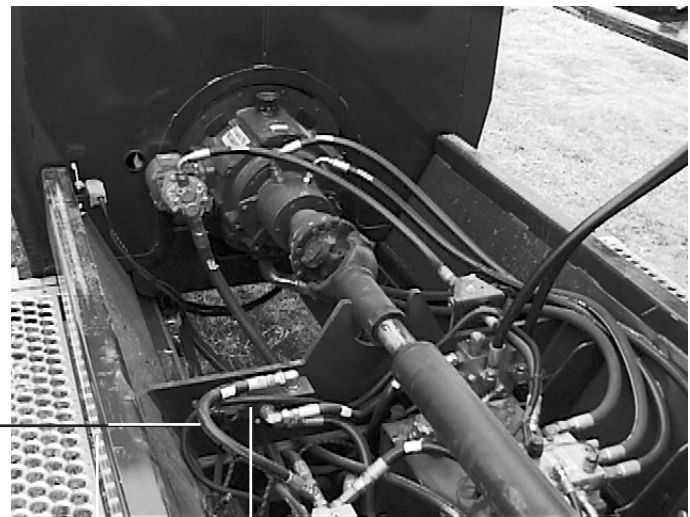


figure 7.3  
location of the  
electro-hydraulic  
valve

location of adjusting nut and jam nut  
found under rubber cap end



electro-hydraulic valve



**IMPORTANT! - DO NOT ENGAGE THE WET CLUTCH AT THIS TIME!**

Turn the adjusting stud clockwise until the tub rotates at the desired speed. Lock the jam nut on the adjusting stud and replace the rubber end cap on the electro-hydraulic valve. When the electro-hydraulic valve is adjusted in this manner, it will function only as a manual flow control. The grinder will now operate as it would if the electronic governor were switched to the tub (manual) mode. The tub speed will be constant and it will not change to match varying load conditions.

Contact your dealer for future repairs or replacement. When the problems are corrected, calibrate the electro-hydraulic valve.



## 6.2 General Troubleshooting (REV. 01-03)

### general troubleshooting

PROBLEM	CAUSE	REMEDY
1. No grinding capacity	<ol style="list-style-type: none"> <li>1. The screen is plugged.</li> <li>2. The hammers or screens are badly worn.</li> <li>3. Materials are too light or fluffy.</li> </ol>	<ol style="list-style-type: none"> <li>1. Clean out the holes in the screen.</li> <li>2. Replace or turn worn parts.</li> <li>3. Mix the lighter material with heavier material.</li> <li>4. Use a larger screen.</li> </ol>
2. The tub slows down or turns slowly.	<ol style="list-style-type: none"> <li>1. The electronic governor is not adjusted properly.</li> <li>2. The electronic governor system malfunctions.</li> <li>3. The hydraulic pressure is low.</li> </ol>	<ol style="list-style-type: none"> <li>1. See the sections on the electronic governor in the operations section of this manual.</li> <li>2. See Troubleshooting the electronic governor in this manual.</li> <li>3. Look for internal leakage or wear in the orbit motor or pump.</li> </ol>
3. The machine vibrates excessively.	<ol style="list-style-type: none"> <li>1. A hammer is broken.</li> <li>2. The rotor bearing is defective.</li> <li>3. The driveline is worn or misaligned.</li> <li>4. Foreign material is wrapped in the rotor.</li> <li>5. The hammer pattern is incorrect.</li> </ol>	<ol style="list-style-type: none"> <li>1. Replace the broken hammer. See page 57 for more information about replacing hammers.</li> <li>2. Replace the rotor bearing.</li> <li>3. Replace worn part or the complete driveline.</li> <li>4. Remove the foreign material.</li> <li>5. See page 57 for more information about replacing hammers.</li> </ol>
4. The engine loses excessive RPM's before the tub stops.	<ol style="list-style-type: none"> <li>1. The electronic governor is not adjusted properly.</li> </ol>	<ol style="list-style-type: none"> <li>1. See the sections on the electronic governor in the operations section of this manual.</li> </ol>
5. The tub stalls.	<ol style="list-style-type: none"> <li>1. The tub hydraulic system, pressure relief valve is set too low.</li> <li>2. The tub is overloaded due to wet or tough grinding materials.</li> <li>3. Too much material in the tub.</li> <li>4. The tub is binding.</li> <li>5. The hydraulic oil is too hot causing electronic governor valve to bind.</li> </ol>	<ol style="list-style-type: none"> <li>1. Readjust the pressure relief valve to 2,500 PSI max.</li> <li>2. Reduce amount of material in tub or shift the hydraulic tub drive to low range.</li> <li>3. Reduce the amount of material in tub.</li> <li>4. Remove material buildup between the tub and the platform framework.</li> <li>5. Reduce the load on the hydraulic system, or stop and allow the hydraulic oil to cool.</li> </ol>
7. The hydraulic oil overheats.	<ol style="list-style-type: none"> <li>1. Pressure relief valve in control valve set too low</li> <li>2. The tub is overloaded.</li> <li>3. Worn pump, control valve, hyd. motors, etc.</li> </ol>	<ol style="list-style-type: none"> <li>1. Readjust the pressure relief valve to 2,500 PSI max.</li> <li>2. Reduce the amount of material in the tub.</li> <li>3. Rebuild or replace the hydraulic components as necessary.</li> </ol>



### 6.3 Troubleshooting Omnex Wireless Remote Controls (REV. 08-06)

The OMNEX ORIGA is a portable, long range, programmable, 8-channel radio remote control unit for 10 to 32VDC operated fixed and mobile equipment. Designed as a safe, compact and easy-to-use radio remote control, the ORIGA puts complete control where it is needed most: with the operator.

#### TROUBLESHOOTING THE OMNEX ORIGA

##### THE REMOTE RADIO CONTROLLER (T100)/TRANSMITTER

PROBLEM	CAUSE	REMEDY
Flashing red LED.	Battery power level is less than 20%.	Replace batteries.
Flashing red and yellow LEDs flashing at same speed.	T100 (remote controller) is in Program mode.	Press red button to close Program mode.
Yellow LED does not flash when buttons 1-8 are pressed.	T100 not activated / Batteries are dead.	Initiate appropriate power on sequence / Replace batteries.
Yellow LED flashes when button is pressed, but machine has shut off.	Out of range.	Relocate closer to machinery; restart the grinder.

##### THE REMOTE RADIO RECEIVER (R100e)

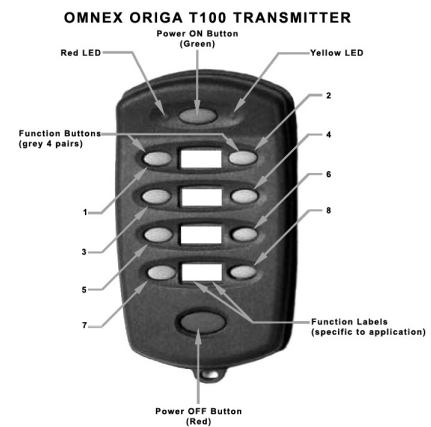
PROBLEM	CAUSE	REMEDY
OUT LED is extinguished.	No power to the R100e (Receiver).	Check power source.
SETUP Yellow LED illuminated.	R100e is in Program mode.	Allow R100e to timeout after 20 seconds.
Green LINK LED does not flash when transmitter is ON.	R100e does not have the correct ID - not likely on a new system - may occur where either the transmitter or the receiver is replaced individually.	Initiate SETUP sequence - see SYSTEM SERVICE.
STATUS Red LED is flashing.	Incorrect input voltage.	Check power source.
STATUS Red LED is steady.	Permanent internal fault.	Disconnect R100e and return unit to manufacturer for repair.
STATUS Green LED is flashing.	Output shorted.	Check wiring.
Output LEDs do not light up when activated.	Output shorted.	Check wiring, relays, and solenoids.



## PROGRAMMING A REPLACEMENT TRANSMITTER

To program a replacement transmitter, complete the following steps:

1. Power up the R100E Receiver and verify that the Green Status LED and the Red E-Stop LED are on steady.
2. Power up the T100 Transmitter into Programming Mode by Pressing and holding the RED E-Stop button and then the Green Power Button at the same time. This will power up the T100 into Programming Mode. The Yellow LED to the right of the GREEN Power Button will begin flashing slowly, (once per second).
3. Enter the Programming Password Code by pressing buttons (functions) (3, 1, 4, 2) and then press the GREEN Power button once. The Yellow LED to the right of the GREEN Power Button and the Red LED to the left of the GREEN Power button will begin flashing rapidly.
4. Enter the programming values. The programming values for DuraTech are 1266888888 (1266228888 for remote throttle option).
5. Press and hold the SETUP button on the R100E Receiver (approx. 5 sec.). The Yellow Setup LED will start flashing slowly while the R100E Receiver enters into programming mode. Once the Yellow Setup LED on the R100E Receiver begins to flash rapidly, release the SETUP button. The R100E is now ready to receive the programming information from the T100 Transmitter.
6. Press and release the GREEN Power Button on the T100 to start sending the Programming information to the R100E Receiver. The Green Link LED on the R100E Receiver will begin to flash, and the Green Status LED on the R100E Receiver will be ON steady. Wait for the Link LED to stop flashing, for the Status LED to begin flashing, and for the transmitter to shut off. This signifies that the programming information has been successfully sent from the T100 Transmitter to the R100E Receiver.
7. Momentarily Power OFF the R100E Receiver and wait for 5 seconds, then power up the R100E Receiver again. The new program settings will now take effect.
8. Press the GREEN Power Button on the T100 Transmitter and observe that the Yellow LED to the right of the GREEN Power Button of the T100 Transmitter will begin flashing. Also note that the Green Link LED on the R100E Receiver is flashing and the Green Status LED on the R100E Receiver is on steady. You are now ready to operate your T100/R100E system.



## OUT OF RANGE/LOSS OF SIGNAL

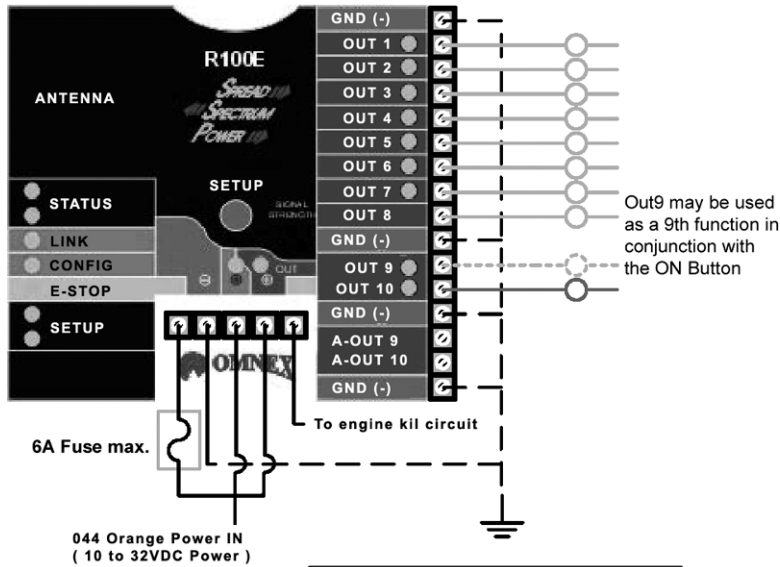
The range of the OMNEX ORIGA is approximately 1,200'. Under certain circumstances, such as low or dead batteries, loss of signal can occur within that distance. In the event that loss of signal occurs, the transmitter will shut off, and the engine will be shut off by the engine kill circuit.



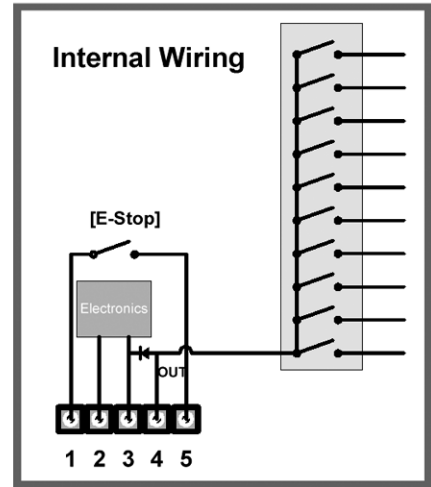
## REPLACING BATTERIES

Install batteries by removing the battery cover using a slotted screwdriver and inserting 4 “AA” Alkaline batteries. Orientation for batteries is embossed inside the battery housing.

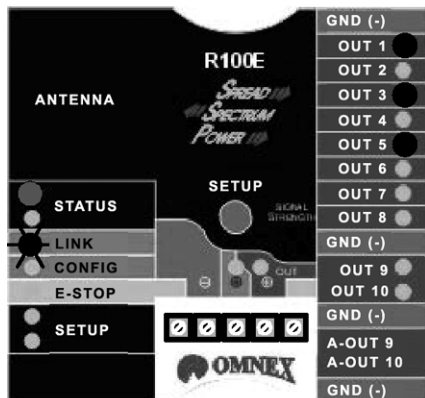
## WIRING SCHEMATIC FOR THE R100e RECEIVER



**NOTE:** Although the Outputs are rated at 10A, the [E-Stop] relay is only 6A and therefore must be fused appropriately



- LED Not Lit
- LED Flashing
- LED Lit Constantly

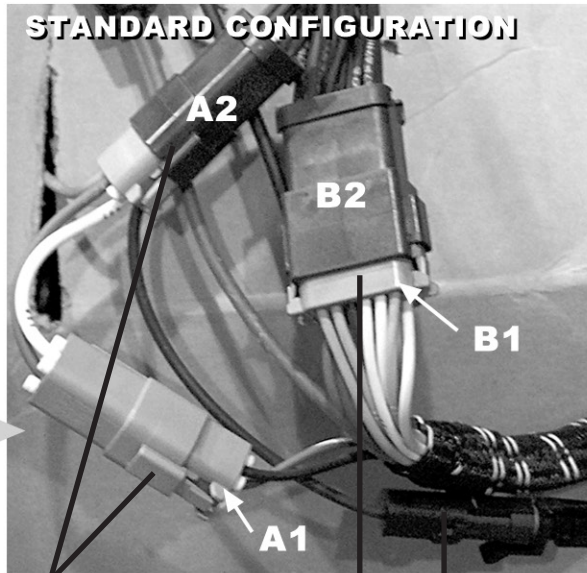
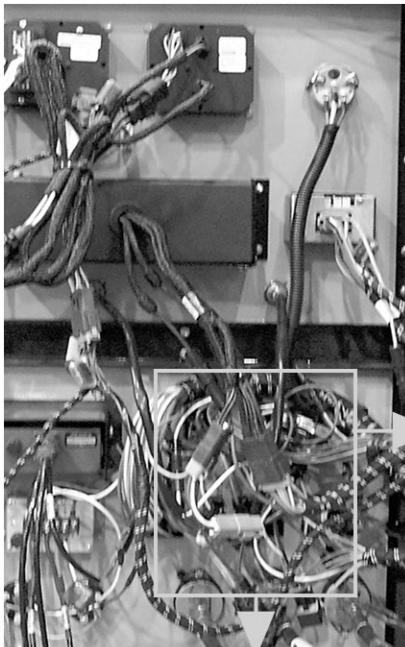






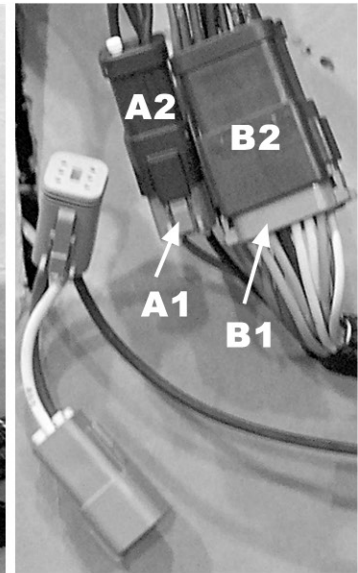
## 6.4 Troubleshooting The Caterpillar Tier I Engine (REV. 04-11)

Caterpillar engine Duratech wiring bypass connections



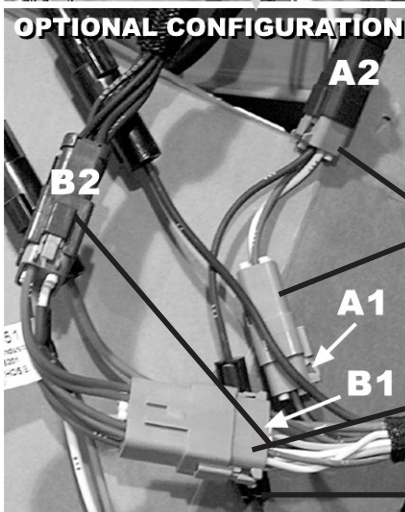
jumper wire set "A"  
(6 pin connectors)

O45 connector



above graphic shows  
Duratech wiring removed for  
Caterpillar engine diagnosis

location jumper wire set "B" (12 pin connector)  
(note: there is only one 12 pin connector in the standard  
configuration.)



jumper wire set "A"  
(6 pin connectors)

jumper wire set "B" (12 pin connectors)  
(note: there are 2-12 pin connectors in the optional configuration.)

O45 connector



**NOTE:** That the wires for connectors A2 and B2 come out of the ignition switch section of the panel.

Several connections are made to connect the Duratech wiring to the Caterpillar wiring.

If the Caterpillar engine requires troubleshooting, the Duratech connections can be removed during the diagnosis.

Jumper wire set "A" is standard on all machines; jumper wire set "B" is used with certain options only, and is **NOT** used on all machines.

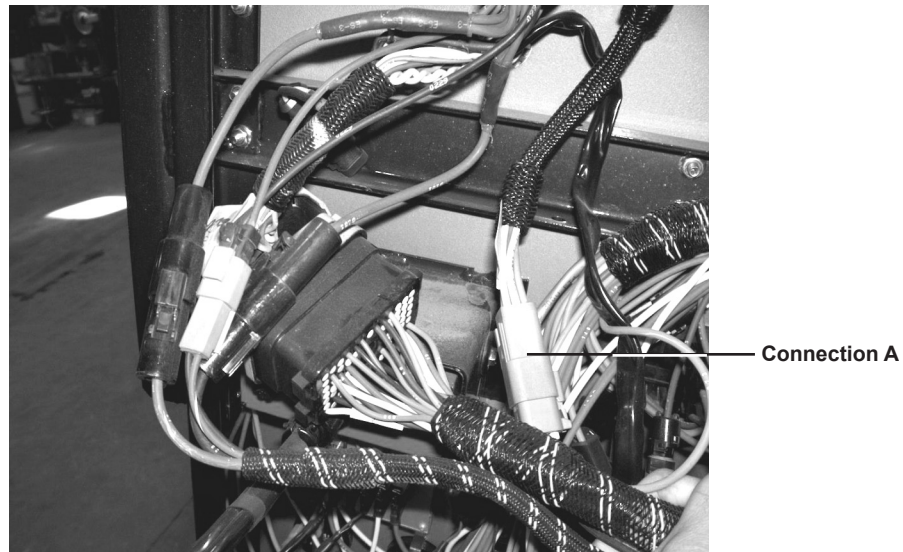
To remove Duratech wiring for Caterpillar engine diagnosis in a system with the 'STANDARD CONFIGURATION', disconnect both "A" six pin connectors and reconnect "A1" to "A2". For a system with the "OPTIONAL CONFIGURATION" disconnect both "A" six pin connectors and both "B" 12 pin connectors, then reconnect "A1" to "A2" and "B1" to "B2".

There is a 15 Amp fuse or circuit breaker in Caterpillar wiring near the starter.





## 6.5 Troubleshooting The Caterpillar C9 and C15 Tier III Engines and The Caterpillar C27 Tier II Engine (REV. 04-11)



One connector is used to connect the DuraTech wiring harness to the Caterpillar wiring.

If the Caterpillar engine requires troubleshooting, the DuraTech connection can be removed during the diagnosis. To remove the DuraTech wiring for Caterpillar engine diagnoses disconnect connection A.

There is a 15 Amp fuse or circuit breaker in the Caterpillar wiring harness near the starter



# 3010EL Electric Tub Grinder Operators Manual Supplement

This is a supplement to the 3010 Tub Grinder Operators Manual. The main part of this book applies to this Tub Grinder except where described in this attached supplement.

## Before Starting the 3010EL Electric Tub Grinder review all:

- Safety Recommendations – See **Section 1** of this operator’s manual
- Pre-Operation – See **Section 3** of this operator’s manual
- *Soft Starter Instructional Manual* – for all information regarding the soft start controller.

## Supplement Section 1: Start-Up (REV. 04-11)



**Warning:** Make sure that all safety measures have been taken before switching on the power supply.

At Start up it is recommended that the rotor motor (labeled ‘ROTOR’) be started first and then the hydraulics motor (labeled ‘HYDRAULICS’). This will keep the amount of electricity used at initial startup down.

1. Before starting the 3010EL Electric Tub Grinder make sure that “**SS bypass**” switch in the soft start panel is set on “**Off**”.
2. Shout the word “**CLEAR**”.



**Note:** Bypass is to be used only if starter fails. Leave bypass “off” for normal operations. This Allows starting if the soft starter fails. This is a DIRECT LINE START! Current will be about 700% of full load amps.



**Note:** Next step will bring grinder up to full operating RPM



**Note:** That the 3010 Rotor Panel is **NOT** equipped with a “**SS bypass**”, but the 3010 Hydraulic panel is equipped with an “**SS bypass**” switch.

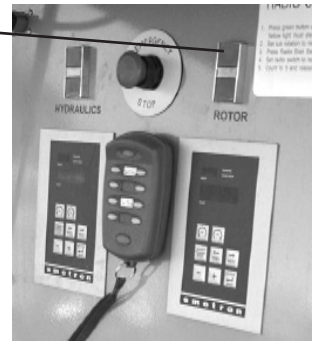


- Then press the start button for the main electrical motor (labeled 'ROTOR'). The start button can be found in two different places, on the control panel marked rotor or on the large soft start panel.

Large soft start panel start button

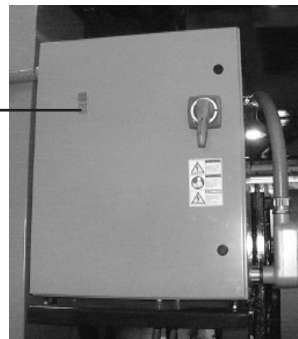


Start button ROTOR

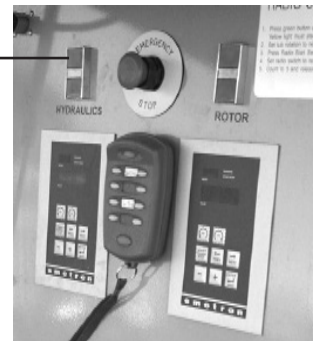


- Then press the start button for the electrical motor that runs the hydraulic pump. This can also be found in two different places, on the control panel marked 'HYDRAULICS' or on the smaller soft start panel for the 75 Hp motor.

Small soft start panel start button



Start button HYDRAULICS



**Note:** Electric motor will not start if platform is raised.

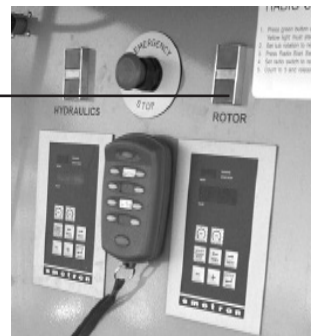
## Supplement Section 2: Shut-Down Procedure (REV. 04-11)

- Run 3010EL Electric Tub Grinder until discharge conveyor is empty, and grind as much of the material in the tub as possible.
- Push stop button. For the rotor motor the button is located on the control panel marked 'ROTOR', and on the large soft start panel.

Large soft start panel stop button



Stop button ROTOR





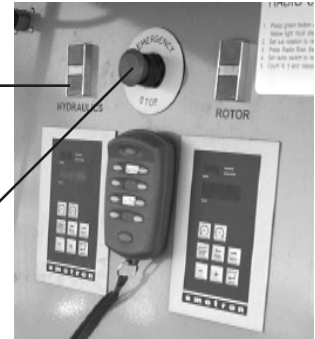
- Then press the stop button for the electrical motor that runs the hydraulic pump. This can also be found in two different places, on the control panel marked 'HYDRAULICS' or on the smaller soft start panel for the 75 Hp motor.

Small soft start panel stop button



Stop button HYDRAULICS

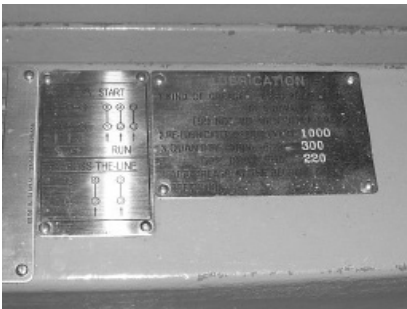
Emergency stop



**'EMERGENCY STOP'** shuts off both motors at the same time. Only use if it is an emergency.

### Supplement Section 3: Lubrication (REV. 04-11)

The Teco-Whitewestinghouse Motor that powers the rotor *requires* the use of **Esso Polyrex Em** or equivalent grease. The (2) grease zerks on this motor must be re-lubricated every 1000 hours. 300 grams of grease is to be placed in the drive end zerk. 220 grams required for end opposite the drive. **DO NOT OVER GREASE!**



Locations of the grease zerks are shown below:

Front location (top of motor)

Drive end location (top of motor)



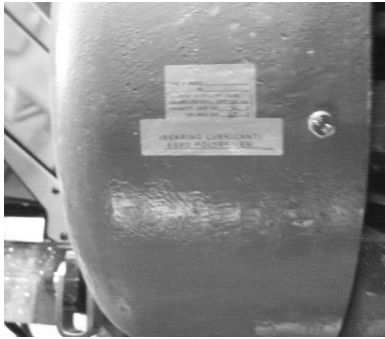
zerk



zerk

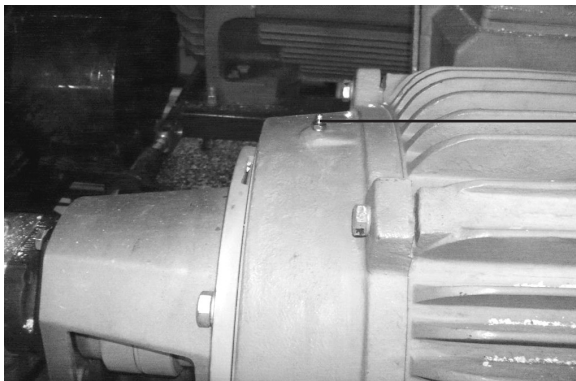


The Teco-Whitewestinghouse Motor that powers the hydraulic pump *requires* the use of **Esso Polyrex Em** or equivalent grease. The (2) grease zerks on this motor must be re-lubricated every 2000 hours. 130 grams of grease is to be placed in the drive end zerk. 65 grams required for end opposite the drive. **DO NOT OVER GREASE!**



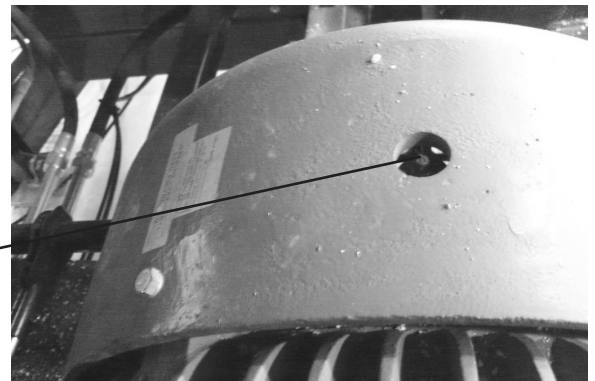
Locations of the grease zerks are shown below:

Front location (top of motor)



zerk

Drive end location (top of motor)



zerk

**Supplement Section 4: Raising/lowering the tub platform, raising/lowering the discharge conveyor, and folding/unfolding the discharge conveyor.** (REV. 04-11)

A 75Hp electric motor powers a hydraulic pump which provides hydraulic oil to raise/lower the tub platform, raise/lower the discharge conveyor, and fold/unfold the discharge conveyor, tub forward/reverse and conveyor forward.





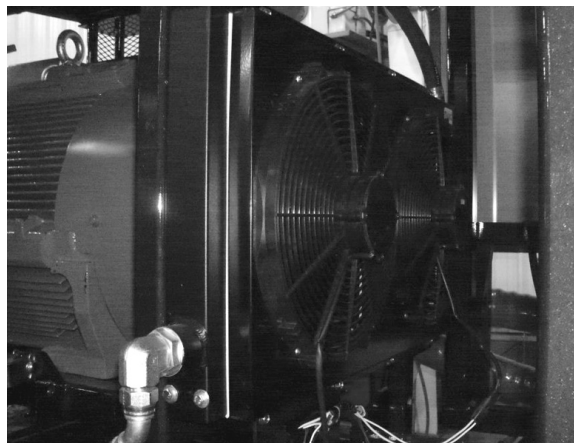


The 75Hp electric motor has its own soft start panel with start and stop buttons on the front of it. At startup of the grinder, it is recommended that the main electrical motor be started first and then the 75 Hp electric motor. This will keep the amount of electricity used at initial startup down. This motor can also run by itself during maintenance and set up.



### Supplement Section 5: Hydraulic cooler (REV. 04-11)

The 3010EL electric grinder is equipped with DC motor driven hydraulic oil cooler to provide supplemental cooling of the hydraulic oil. The fan on the cooler is driven by a DC electric motor. The fan on/off and direction is regulated by a controller based on the oil temperature.



### Indicator LED's

The controller has 2 LED's which display the system status. The green LED will light when power to the system is applied and no errors are detected. The red LED will blink if there are faults to the output (fan motor). The output is monitored for no-load or overload conditions. If a fault condition occurs, count the number of blinks of the red LED, then refers to the error codes below:

**RED ERROR CODE LED BLINKS:**

- 1 TIME = FAN "A" OVERLOAD
- 2 TIMES = FAN "A" OPEN
- 3 TIME = FAN "A" OVERLOAD
- 4 TIMES = FAN "A" OPEN

**FAN "A" - HAS YELLOW(+) AND WHITE(-) WIRES**

**FAN "B" - HAS GREEN(+) AND BLUE(-) WIRES**

Indicator LEDs



### Explanation:

- 1 The controller is overheating. Either the fan is drawing more current than it should, or the controller is not being cooled sufficiently.
- 2 The fan is not connected. Check for broken wires. The minimum current draw must be 2A to keep the system from showing an error.





## Supplement Section 6: Control Panel (REV. 04-11)

The control panel for the 3010EL electric tub grinder is located on the right hand side of the machine. Controls on the panel include; engine start, engine stop, emergency kill switch, throttle, tub controls, conveyor on/off, conveyor positioning, rotor engage button, rotor disengage button, tub governor, tub tilt, grinding hours and job hours reset button.



### Top Control Panel

The top control panel includes a start/stop button and a programming pad for each electric motor.

Radio remote operates the same as in the main part of this operator’s manual except there is no remote stop for this operation.

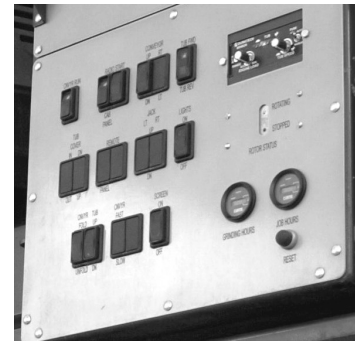
### Bottom Control Panel

Bottom control panel operates the same as described in the main part of this manual.

If your machine is equipped with a Hydraulic Rod Puller:

On the bottom control panel, if the switch is flipped to “MAIN” the standard functions will work. If the switch is flipped to “ROD PULLER” the rod puller will work.

The rod puller is activated by a removable pendant (switch box) shown below.





**Supplement Section 7: Belt Deflection** (REV. 04-11)

3010 electric

Input power 600 HP

Design power 720 HP

50 Hz

21.2" dia driver, 15" dia driven.

100" belt

0.33" deflection

New belt deflection force 48-51 lb

Used belt deflection force 42-45 lb

60 Hz





## Appendix A: Warranty

DuraTech Industries International Inc. warrants to the original purchaser for 1 year from purchase date that this product will be free from defects in material and workmanship when used as intended and under normal maintenance and operating conditions. This warranty is limited to the replacement of any defective part or parts if DuraTech Industries is notified within thirty (30) days of failure.

This warranty shall become void if in the judgment of DuraTech Industries International, Inc. the machine has been subject to misuse, negligence, alterations, damaged by accident or lack of required normal maintenance, or if the product has been used for a purpose for which it was not designed.

All claims for warranty must be made through the dealer which originally sold the product and all warranty adjustments must be made through same.

This warranty does not apply to tires, bearings, batteries, engines, or any other trade accessories not manufactured by DuraTech Industries International Inc. Buyer must rely solely on the existing warranty, if any, of these respective manufacturers.

DuraTech Industries International Inc., shall **not** be held liable for damages of any kind, direct, contingent, or consequential to property under this warranty. DuraTech Industries International Inc., cannot be held liable for any damages resulting from causes beyond its control. DuraTech Industries International Inc., shall **not** be held liable under this warranty for rental costs or any expense or loss for labor or supplies.

DuraTech Industries International Inc., reserves the right to make changes in material and/or designs of this product at any time without notice.

This warranty is void if any unauthorized modifications or alterations are made to the machine.

This warranty is void if DuraTech Industries International Inc. does not receive a valid warranty registration card at its office in Jamestown, North Dakota, USA, within 10 days from date of original purchase.

All other warranties made with respect to this product, either expressed or implied, are hereby disclaimed by DuraTech Industries International Inc.



# Appendix B: SPECIFICATIONS

## MODEL 3010 DURATECH TUB GRINDER

### General

Weight w/ Pintle Hitch .....	35,840 lbs. (16,257 kg)
Weight w/ Fifth Wheel Hitch .....	38,000 lbs. (17,237 kg)
Transport Width.....	8' 6" (2.59 m)
Transport Height.....	11' (3.35 m)
Transport Length With Fifth Wheel .....	42' 9" (13 m)
Axles .....	(2) 22,500 lbs. (10,206 kg)
Tires .....	255/70R22.5
Fuel Capacity ...	300 gallons (180 gallons with pintle hitch.) (1135.62 l or 681.37 l)
Hydraulic Oil Capacity .....	50 gallons (189.27 l)
Lights.....	Clearance, and directional

### Tub features

Tub Width .....	10' (3.05 m)
Depth .....	46" (117 cm)
Tub Diameter At Base .....	8' (2.44 m)
Tub Wall .....	1/4" thick
Tub Floor .....	3/8" thick AR Steel
Tub Drive .....	120H chain single drive hydraulic motor
Service Access.....	90° hydraulic tilting tub
Discharge Conveyor .....	26' (l) x 30"(w), hydraulic end driven cleated belt
Belly Conveyor .....	30" wide impact resistant
Tub Speed Sensor .....	Electronic self-governing

### Hammermill

Rotor - Shaft Diameter .....	6" stress proof steel
Rotor Length .....	44" (111.76 cm)
Rotor Plates .....	16" diameter x 1-1/2" thick
Feed Opening .....	45" x 25" (114.3 cm x 63.5 cm)
Screen Area .....	2403 sq. in. (1.55 sq. m)
Hammer Rods .....	(8) 1-1/2" diameter
Bearings.....	4" oil bath bearing
Hammermill Drive .....	Direct drive through HPTO oil cooled clutch



## **Options**

Radio remote that features the following commands; tub start-stop, tub forward-reverse, conveyor up-down, and emergency stop.

Air Compressor

Tub Cover









